



Development of an Improved Microwave Ocean Surface Emissivity Radiative Transfer Model

Salem Fawwaz El-Nimri

Central Florida Remote Sensing Laboratory

University of Central Florida

Ph.D. Final Defense

November 2nd, 2009



Presentation Outline



- Objective
- Radiative Transfer Model
- Ocean Emissivity Model Architecture
- Results Parametric Plots
 - ❖ Freq, EIA & Wind Speed dependence
- Summary



Objective



- To develop a unified, physics-based, microwave ocean surface radiometric emissivity model, which is useful over wide ranges of:
 - ❖ Frequency
 - ❖ Wind speed
 - ❖ Earth incidence angle
- Model shall be tuned using all credible surface emissivity data



Model Requirements and Goals



➤ Requirements

- ❖ Model emissivity shall be smoothly varying and monotonic with parameters
 - Freq: 1-40 GHz
 - Goal: 1-200 GHz
 - EIA: 0-70 degrees
 - Goal: 80 deg
 - WS: 0 – hurricane force winds (> 70 m/s)
 - Pol: Linear, Vertical and Horizontal
- ❖ No slope inflections in emissivity versus parameters

Summary



- In the conduct of this dissertation research the following were performed:
 - ❖ Analysis of airborne Stepped Freq Microwave Radiometer (SFMR) brightness temperature (T_b) measurements in hurricanes
 - ❑ Derivation of roughness emissivity at C-band
 - ❑ Derivation of % foam coverage vs. wind speed
 - ❖ Extensive literature search for ocean surface emissivity (theory & measurements)
 - ❑ Tuning of model parameters using published emissivity results



Rational for Unified Emissivity Model



- Retrievals, to measure physical parameters
 - ❖ Ocean surface parameters
 - WS, Salinity, SST
 - ❖ Atmospheric parameters
 - CLW, WV, RR, Atmos Temp
 - Correction for surface effect needed
- Inter-satellite Radiometric Calibration
- Monte Carlo simulation for radiometer instrument design & performance evaluation



Rational Cont.



- No single unified ocean surface emissivity model exists
- Existing models have significant limitations, especially over earth incidence angle (EIA) and surface wind speed range



Microwave Radiative Transfer

Passive Microwave Remote Sensing

In remote sensing applications, non-coherent microwave blackbody radiation collected by the antenna is the desired signal

$$T_{app} = T_{UP} + e^{-\tau} (T_{surf} + T_{ref})$$

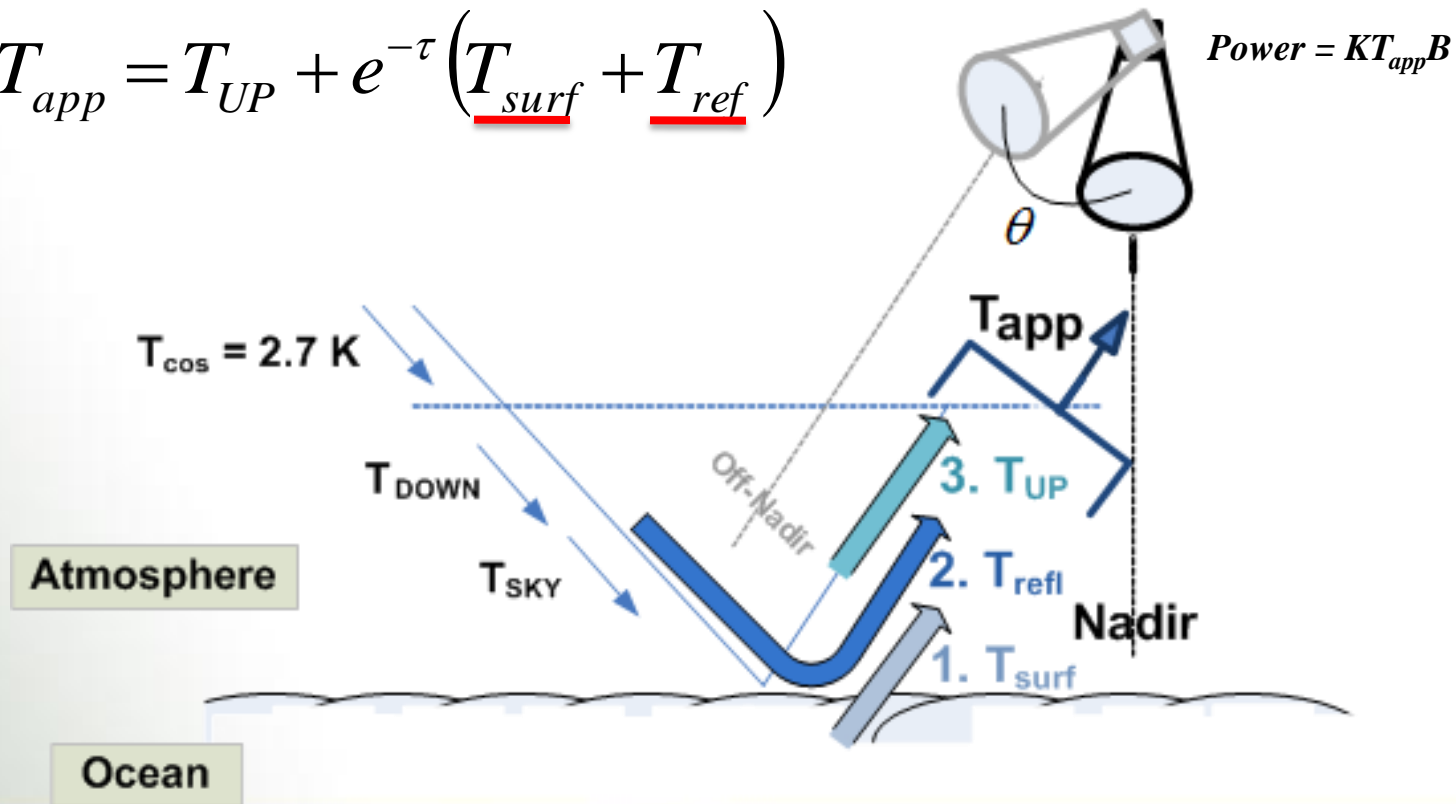

- Total apparent brightness temperature measured by a radiometer

$$T_{app} = T_{up} + e^{-\tau} (T_{surf} + T_{ref})$$

- Sea Surface Emissivity is embedded in T_{surf} and T_{ref}

$$T_{surf} = \varepsilon \times SST$$

$$T_{ref} = (1 - \varepsilon) \times (T_{down} + T_{cos})$$

Existing Ocean Emissivity Models

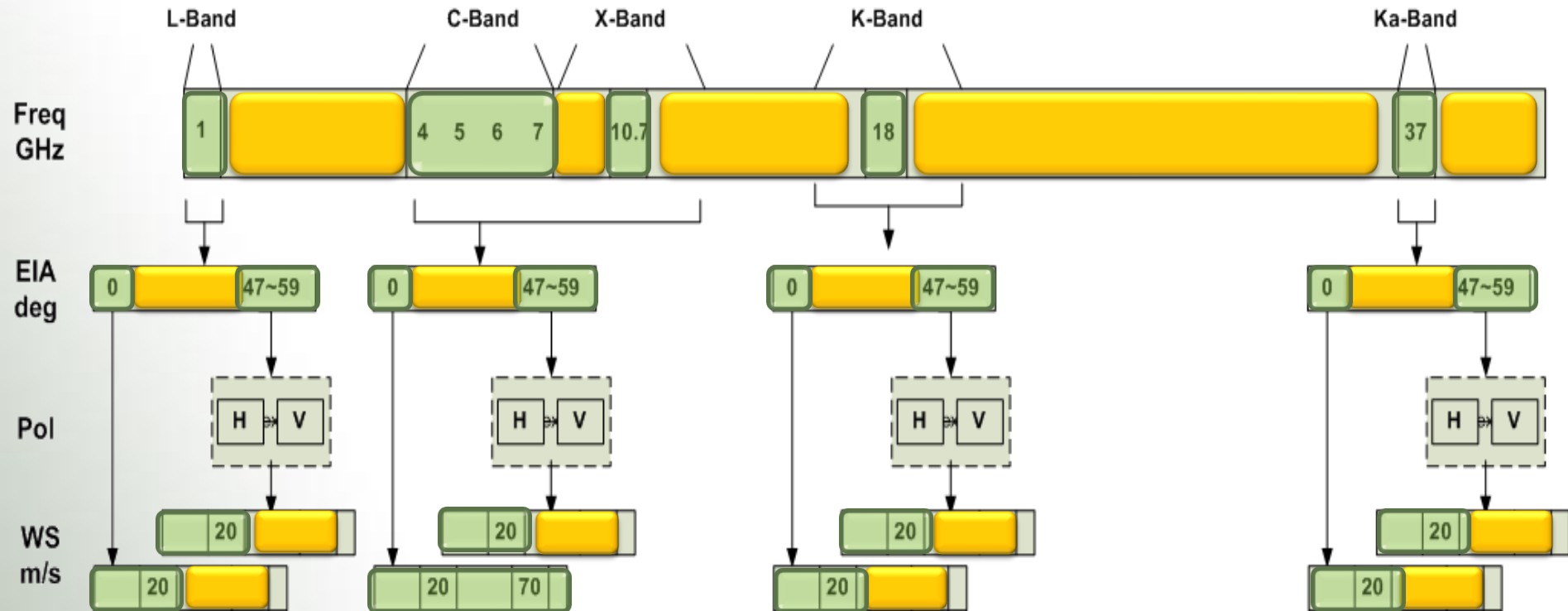

Current Satellite Radiometer Systems

AMSR (Adeos II)
(55°)

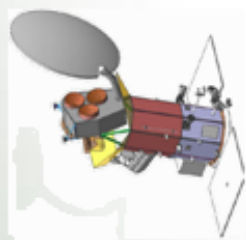
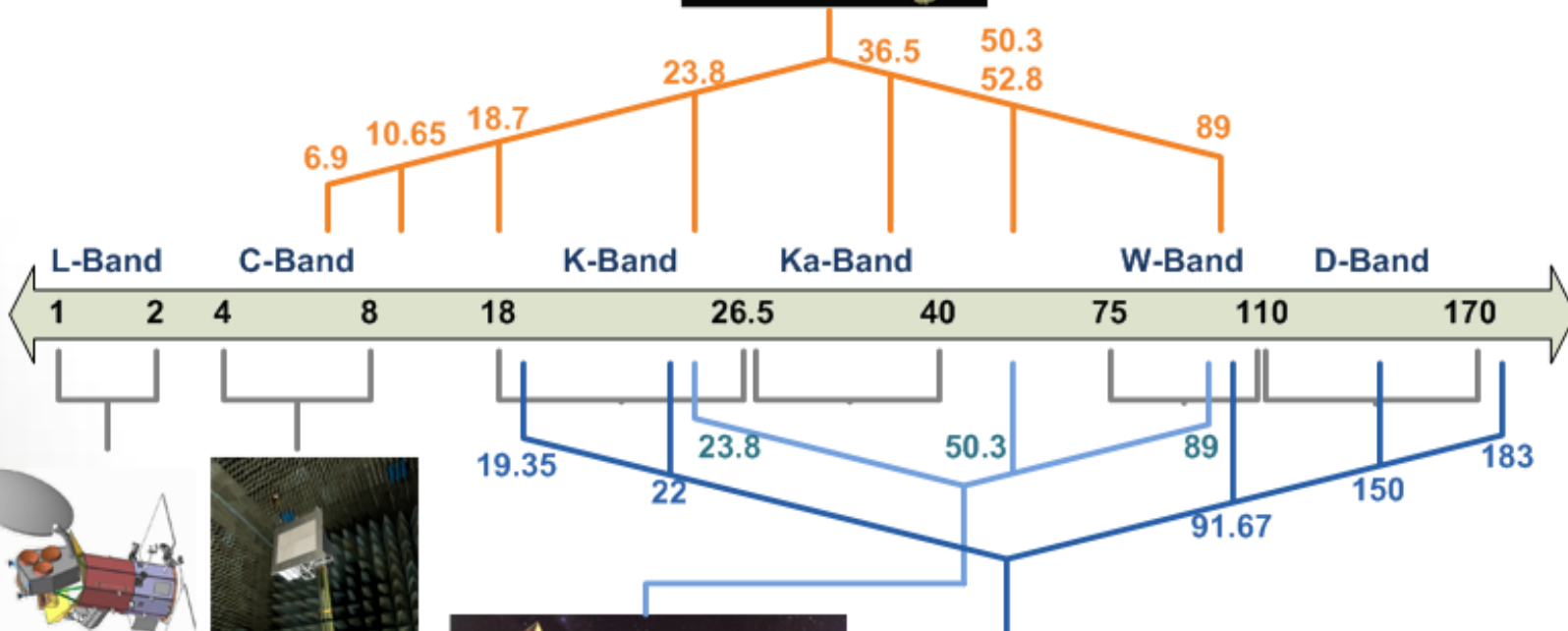
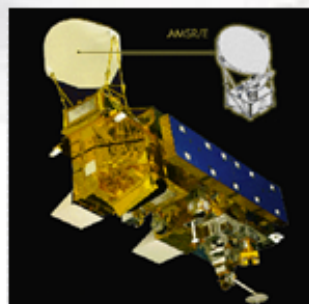

Aquarius
(55°)

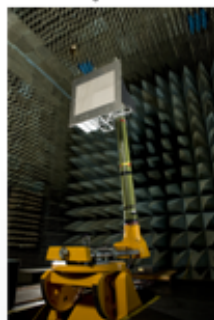

HIRAD
(± 60°)

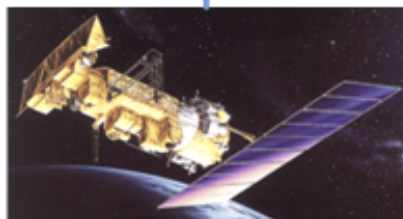

AMSU
(± 49.5°)



SSM/I
(53.1°)



Emissivity Model Architecture

Current Emissivity Models



- Three kinds of emissivity models
 - ❖ Statistical Regression Empirical Models
 - Uhlhorn et. al. (Limited in EIA & Freq)
 - ❖ Semi-empirical Models
 - Meissner & Wentz (Limited in EIA, WS, Freq)
 - Wilheit (Limited in WS)
 - ❖ Physics-Based with empirical coefficients
 - Stogryn

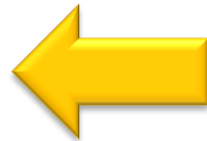

Emissivity Model Architecture



➤ Physics-based

$$\varepsilon_{total} = \varepsilon_{ocean} + \Delta\varepsilon_{WindDirection}$$

$$\varepsilon_{ocean} = (1 - FF) \varepsilon_{rough} + FF \varepsilon_{foam}$$

$$\varepsilon_{rough} = \varepsilon_{smooth} + \Delta\varepsilon_{excess}$$

$$\Delta\varepsilon_{WindDirection} = A_1 \cos(\chi) + A_2 \cos(2\chi)$$

➤ Principal advantage is ability to extend into 3D parameter space

❖ Freq, EIA, WS



$$\varepsilon_{total} = \varepsilon_{ocean} + \Delta\varepsilon_{WindDirection}$$

ε_{ocean}

Ocean Emissivity

$$\varepsilon_{ocean} = FF \varepsilon_{foam} + (1 - FF) \varepsilon_{rough}$$

$$\varepsilon_{rough} = \varepsilon_{smooth} + \Delta\varepsilon_{excess}$$

➤ Empirical Parameters

- ❖ $\Delta\varepsilon_{excess}$
 - ❖ $\varepsilon_{smooth} = (1 - \Gamma)$
 - ❖ FF
 - ❖ ε_{foam}
- } ε_{rough}

Emissivity: Foam-Free Ocean



➤ Represented by

$$(1 - FF) \epsilon_{rough}$$

where

$$\epsilon_{rough} = \epsilon_{smooth} + \Delta \epsilon_{excess}$$

➤ Where

❖ ϵ_{smooth} : Smooth ocean emissivity, $f(e_r, EIA)$

❖ $\Delta \epsilon_{excess}$: Excess emissivity, $f \left(\begin{array}{c} WS \\ EIA \\ freq \\ SST \\ Pol \end{array} \right)$

Smooth Ocean Emissivity



➤ Theoretical Parameters

$$\diamond \varepsilon_{smooth} = (1 - \Gamma)$$

□ Γ : Fresnel power reflection coefficient

$$-\Gamma = 1 - |\rho|^2$$

$$\rho_{V-pol} = - \left[\frac{e_r \cos \theta - \sqrt{e_r - \sin^2 \theta}}{e_r \cos \theta + \sqrt{e_r - \sin^2 \theta}} \right]$$

$$\rho_{H-pol} = \left[\frac{\cos \theta - \sqrt{e_r - \sin^2 \theta}}{\cos \theta + \sqrt{e_r - \sin^2 \theta}} \right]$$

Typical Ocean Power Reflectivity

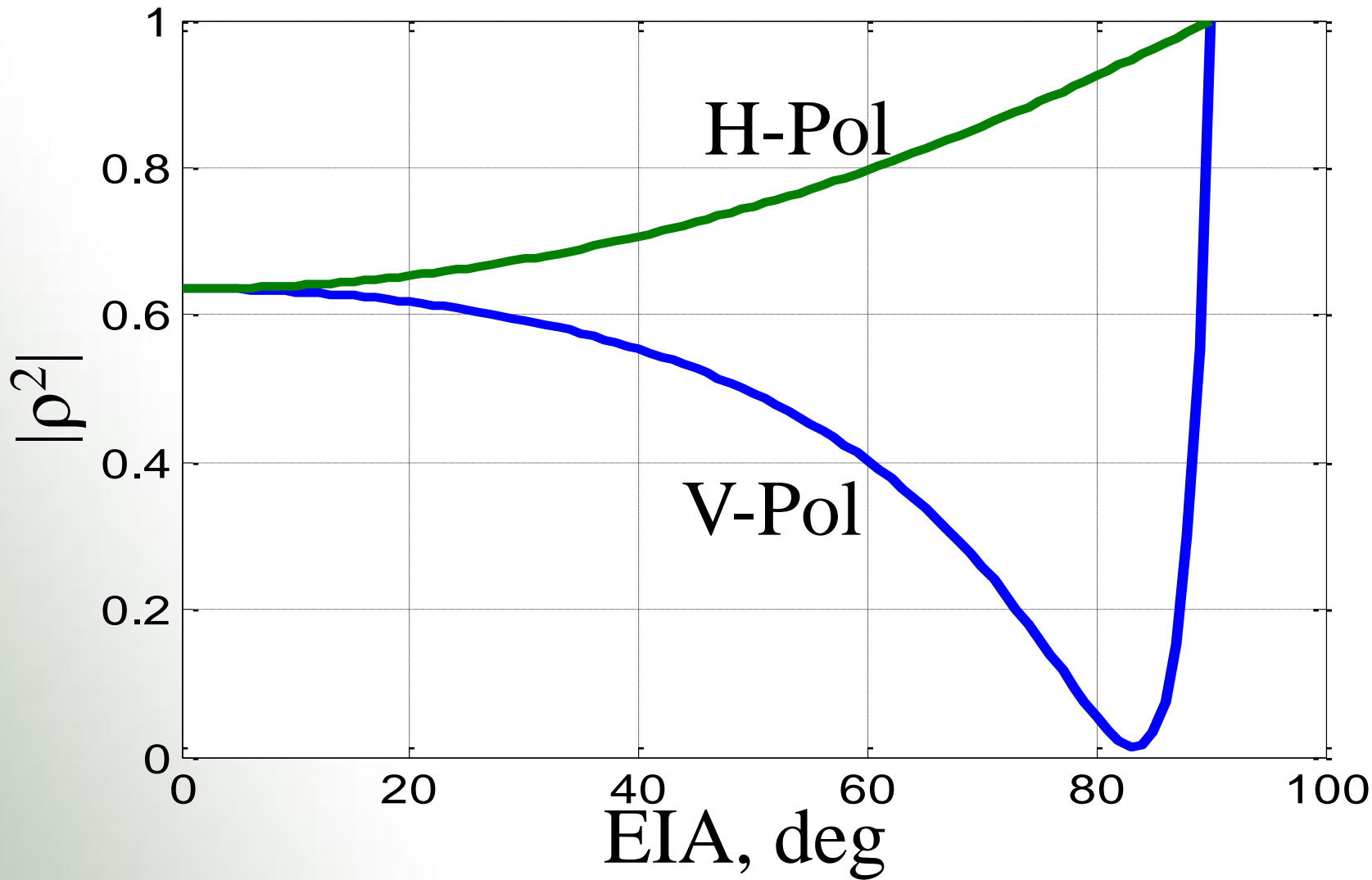

Dielectric Constant Models (ϵ_r)

- Four microwave dielectric constant models were studied
 - ❖ Lane and Saxton (1951)
 - ❖ Stogryn (1971)
 - ❖ Klein & Swift (1977)
 - ❖ **Meissner and Wentz (2000) selected** ←
- Models depend on three parameters:
 - ❖ Sea Surface Temp (physical)
 - ❖ Frequency
 - ❖ Salinity

Sea Water Dielectric Constant

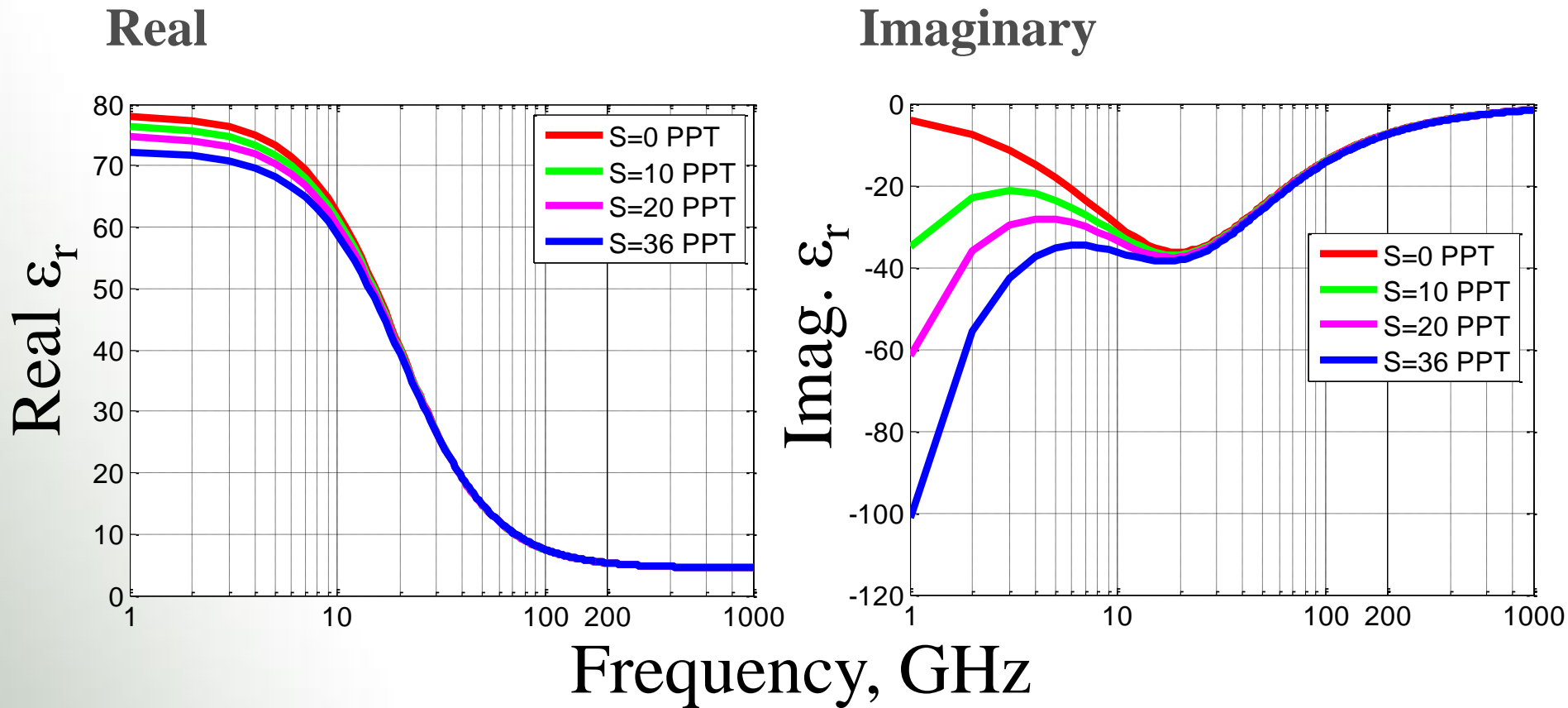

- Saline (0, 10, 20 and 36 ppt)
- Sea surface temperature of (25°C)



Excess emissivity ($\Delta\varepsilon_{excess}$)



➤ The excess emissivity is

$$\Delta\varepsilon_{excess} = f(ws, EIA, freq) \times \frac{1}{SST}$$

❖ Dependence on Sea Surface Temperature (*SST*), was adopted from Alex Stogryn work



Emissivity: Foam-Free Ocean



➤ Modeling based on selected data

❖ Laboratory experiments

- ❑ Alex Stogryn collected experiments

❖ Ocean surface brightness observations

- ❑ Stepped Frequency Microwave Radiometer (SFMR)

❖ Total emissivity

- ❑ Tran et. al. derived emissivity from Topex/Poseidon Microwave Radiometer (TMR)
- ❑ Messiner and Wentz derived emissivity from Special Sensor Microwave/Imager (SSM/I)

Rough Emissivity @ Nadir for 7 GHz

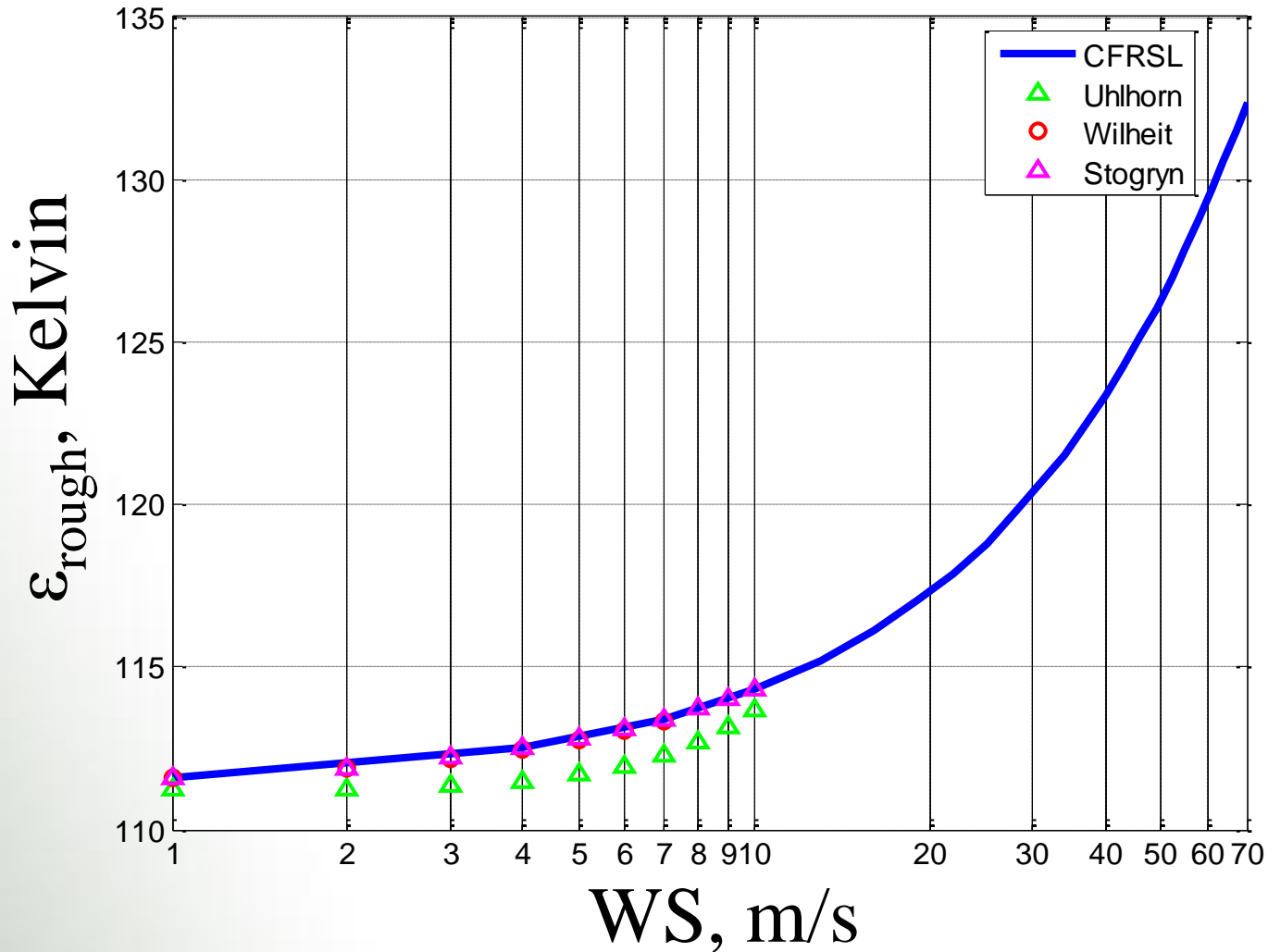

Rough Emissivity @ 53 deg for 7 GHz



➤ H-Pol

➤ V-Pol

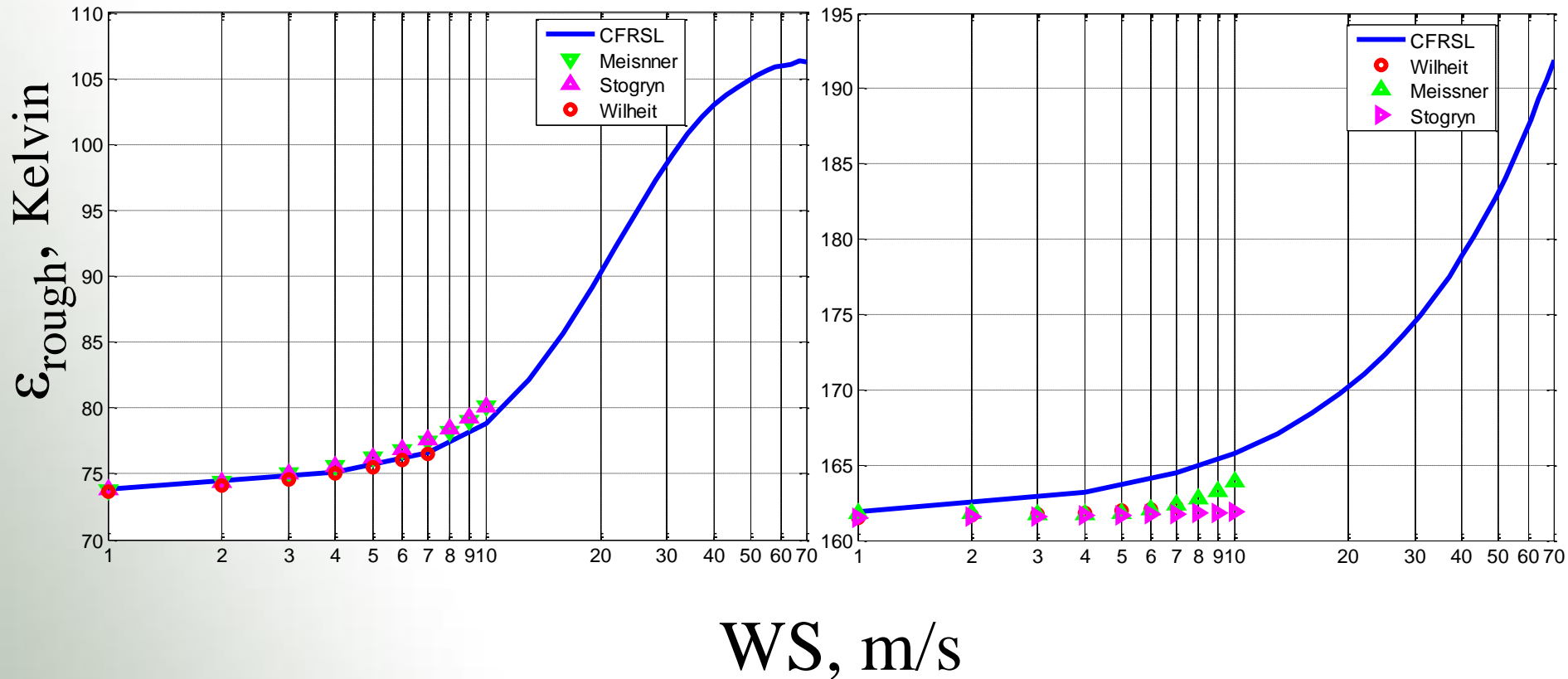

Ocean Emissivity

$$\varepsilon_{ocean} = FF \varepsilon_{foam} + (1 - FF) \varepsilon_{rough}$$

$$\varepsilon_{rough} = \varepsilon_{smooth} + \Delta\varepsilon_{excess}$$

➤ Empirical Parameters

❖ $\Delta\varepsilon_{excess}$

❖ $\varepsilon_{smooth} = (1 - \Gamma)$

❖ FF

❖ ε_{foam}



Emissivity of Sea Foam



➤ Represented by

$$FF \times \varepsilon_{foam}$$

➤ Where

❖ FF : Foam fraction coverage, $f(ws)$

❖ ε_{foam} : Foam Emissivity,



Foam Fraction (FF) Estimation



- Foam Fraction modeled as $f(WS)$
 - ❖ Independent of frequency & EIA
- Used SFMR nadir ocean surface emissivity model
 - ❖ FF estimated iteratively
 - ❖ Wind speeds to hurricane force winds (Cat. 5)

Foam Fraction (FF) Estimation cont.

- The FF estimation process was iterative

$$\mathcal{E}_{foam} = \frac{\mathcal{E}_{SFMR} - (1 - FF)\mathcal{E}_{rough}}{FF} \Bigg|_{High\ WS}$$

- Then compute FF over all WS range

$$FF = \frac{\langle \mathcal{E}_{SFMR} \rangle_{freq} - \langle \mathcal{E}_{rough} \rangle_{freq}}{\langle \mathcal{E}_{foam} \rangle_{freq} - \langle \mathcal{E}_{rough} \rangle_{freq}} \Bigg|_{nadir}$$

Estimates of Hurricane Foam Fraction

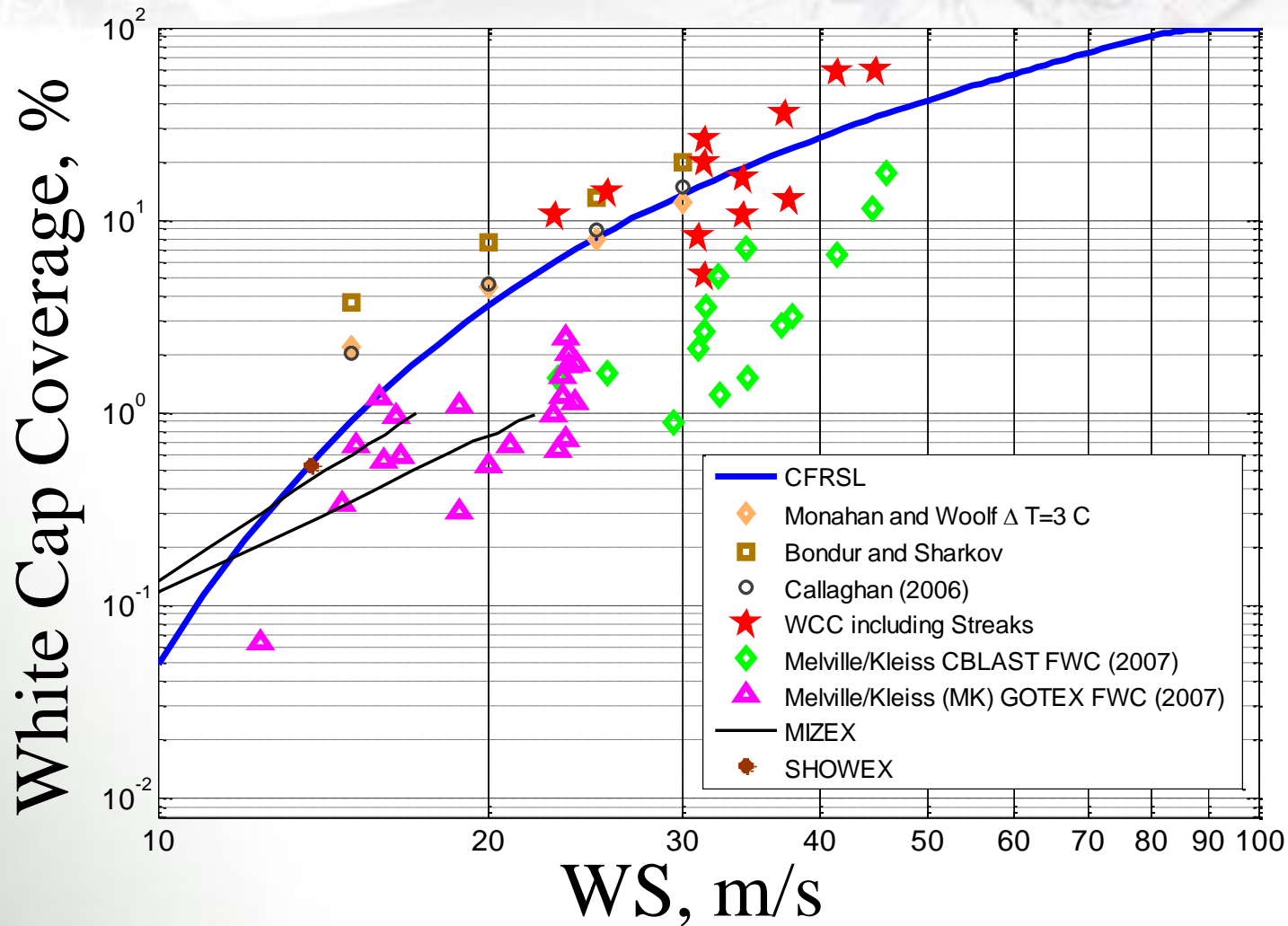

•CFRSL foam fraction model (solid line)



Emissivity of Foam



- Foam modeling based on selected published data
 - ❖ Laboratory experiments & Field Measurements
 - ❑ Foam, Fain, Oil Slicks and GPS Reflectrometry (FROG), Spanish National funds, Camps et. al.
 - L-Band (1.4 GHz)
 - EIA (0-90) degrees
 - ❑ Wave tank experiments by L. A. Rose in 2002,2004
 - Freq : 10.8, 18.7, 37 GHz
 - EIA 53 degrees
 - ❑ Naval Research Laboratory (NRL) Chesapeake Bay Detachment
 - Freq : 10.8 & 36.5 GHz
 - EIA (30 – 60) degrees



Emissivity of Foam cont.



- Zheng et. al Foam emissivity model
 - Freq : 18.7, 23.8, and 34 GHz
 - Nadir

- Other collected observations from the literature
 - Reul et. al.
 - Williams et. al
 - Bordkonskiy et. al.
 - Gue et. al.
 - Zhou et. al.



Emissivity of Foam cont.



- Derived the emissivity of foam at C-band from
 - ❖ SFMR @ high wind speeds
 - SFMR emissivity model @ nadir
 - SFMR Tb measurements during aircraft banked turns
 - » EIA (Nadir ~ 35 degrees)
 - » Data collected from 18 hurricane flights over 3 years
 - Ruf et. al. emissivity model for WindSat hurricane observations (3 Hurricanes)
 - » EIA (53 degrees)



ϵ_{foam}



- The emissivity of foam, ϵ_{foam} , modeled as

$$\epsilon_{foam} = Q(freq) \times f(ws, EIA)$$

- Dependence on foam thickness significant in C-band region
 - ❖ Wind speed used as a proxy for thickness
 - ❖ Thickness effects negligible for higher frequencies

Foam Emmissivity-Zhang et. al

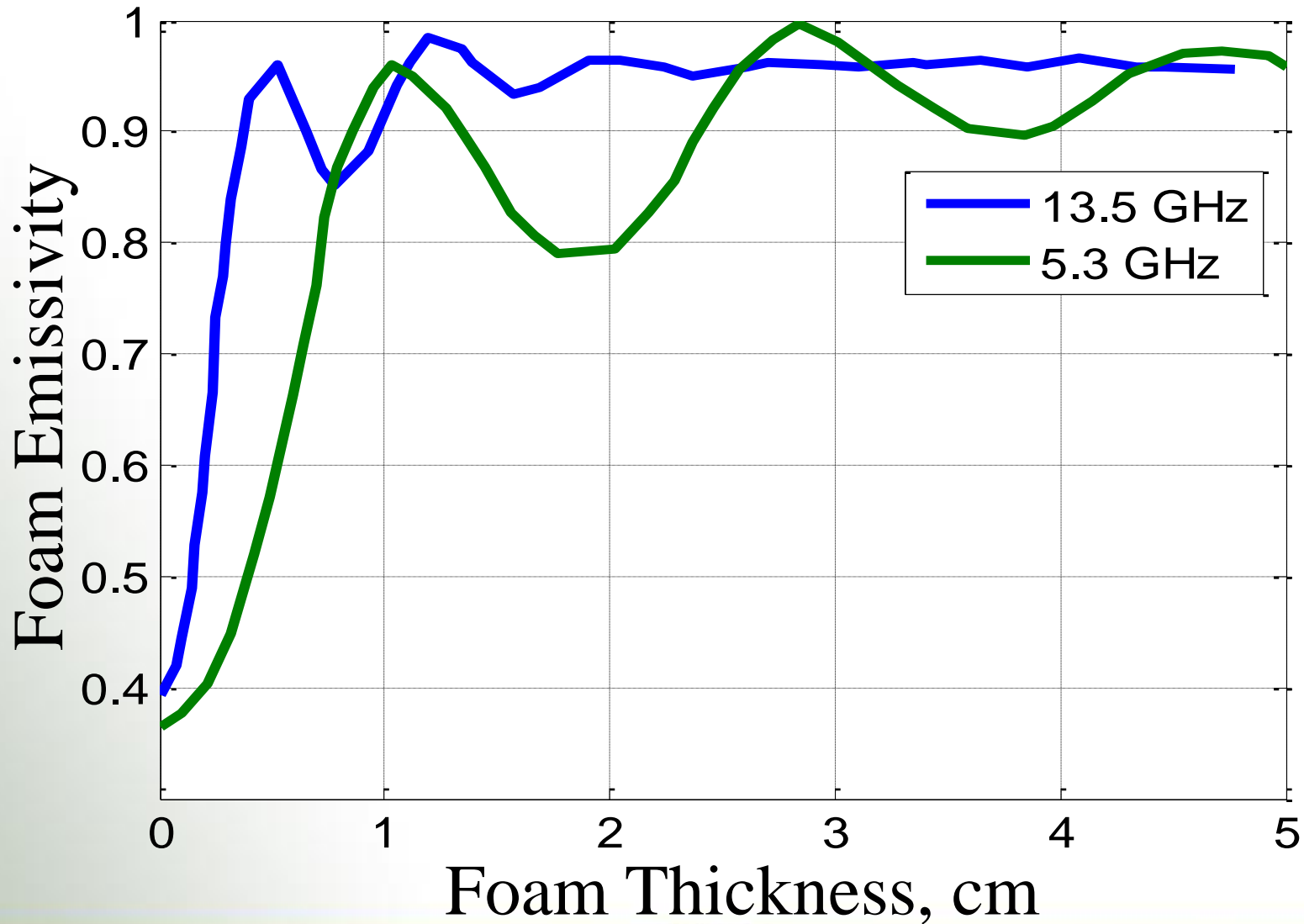

CFRSL Emissivity of Foam at Nadir

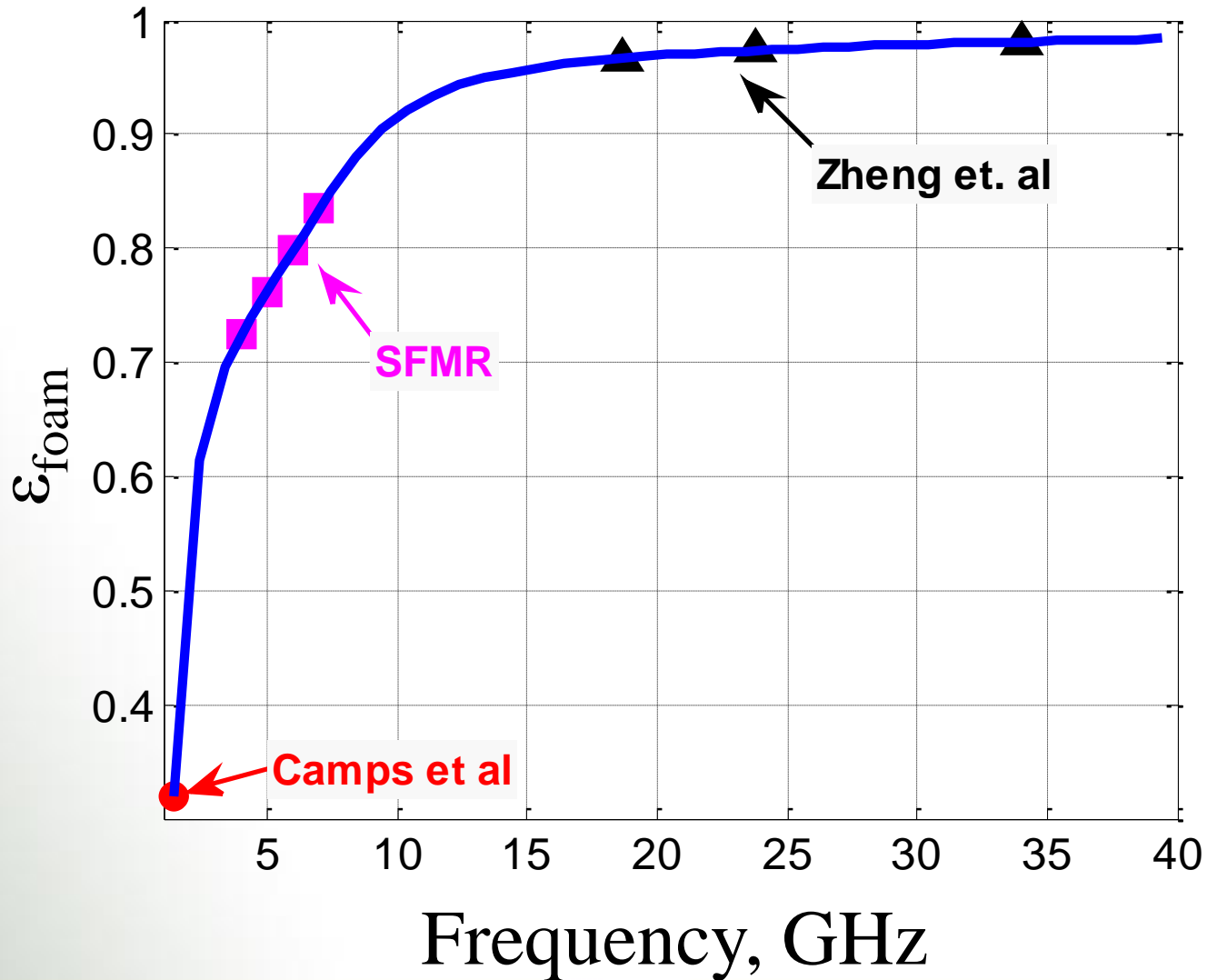

EIA Dependence of Foam Emmissivity



10.8 GHz

36.5 GHz

Emis of Foam

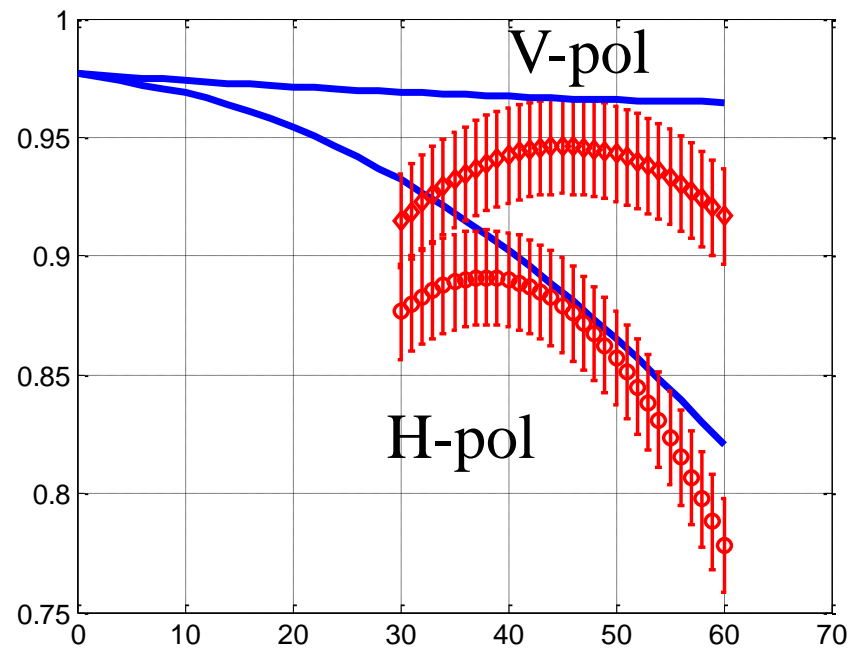
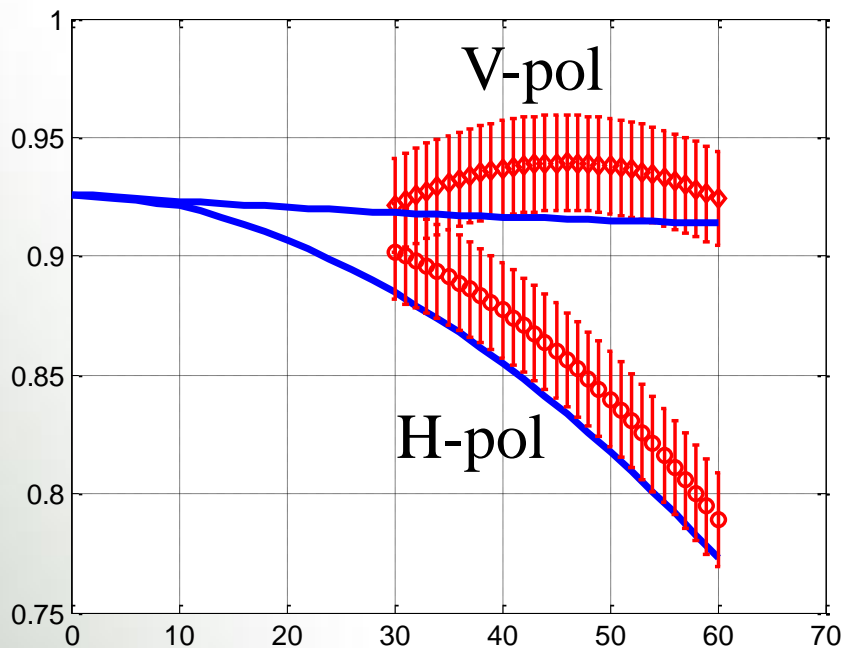

EIA, deg



$$\varepsilon_{total} = \varepsilon_{ocean} + \Delta\varepsilon_{Wind\ Direction}$$

$\Delta\varepsilon_{Wind\ Direction}$

Ocean Wind Direction Effect

➤ Derived from Maxwell's equations

❖ V & H Pol emissions are even periodic functions of the relative wind direction χ ,

$$\Delta \varepsilon_{WindDirection} = A_1 \cos(\chi) + A_2 \cos(2\chi) + \dots$$

Where

A_1 and A_2 are

$$f \begin{pmatrix} freq \\ EIA \\ ws \\ Pol \end{pmatrix}$$

χ is the relative wind direction

defined as: difference between the wind direction and the radiometer (antenna) azimuthal look angle



Wind Direction cont.



➤ Wind directional emissivity modeling based on selected data

❖ Ocean surface observations

❑ Topexposeidon Microwave Radiometer (TMR)

- Freq : 18, 21, 37 GHz
- Nadir Observations

❑ Aircraft S-band measurements in Pacific ocean and Barents sea Trokhimovski et. al.

- Freq: S-band (2.65 GHz)
- Nadir Observations



Wind Direction cont.



- Satellite radiometer observations (F. Wentz, ReMSS, 2000)
 - Freq : 11, 19, 37 GHz
 - EIA : 53 degrees

- WindSat wind direction observations
 - Freq: 10.7, 18.7, 37 GHz
 - EIA: 53 degrees

Wind Direction First Harmonic at Nadir

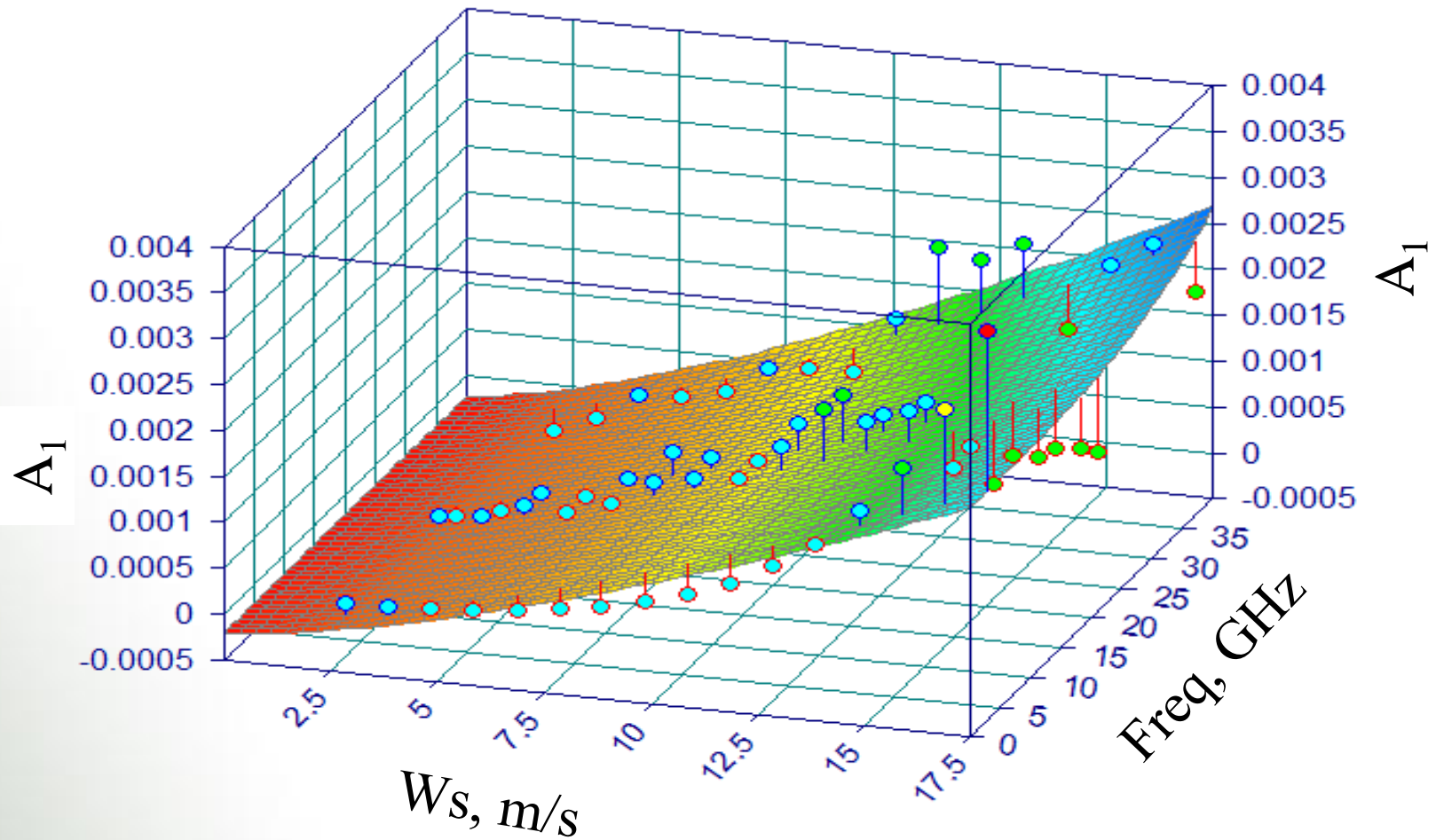

Wind Direction First Harmonic at 53 degrees, V-Pol

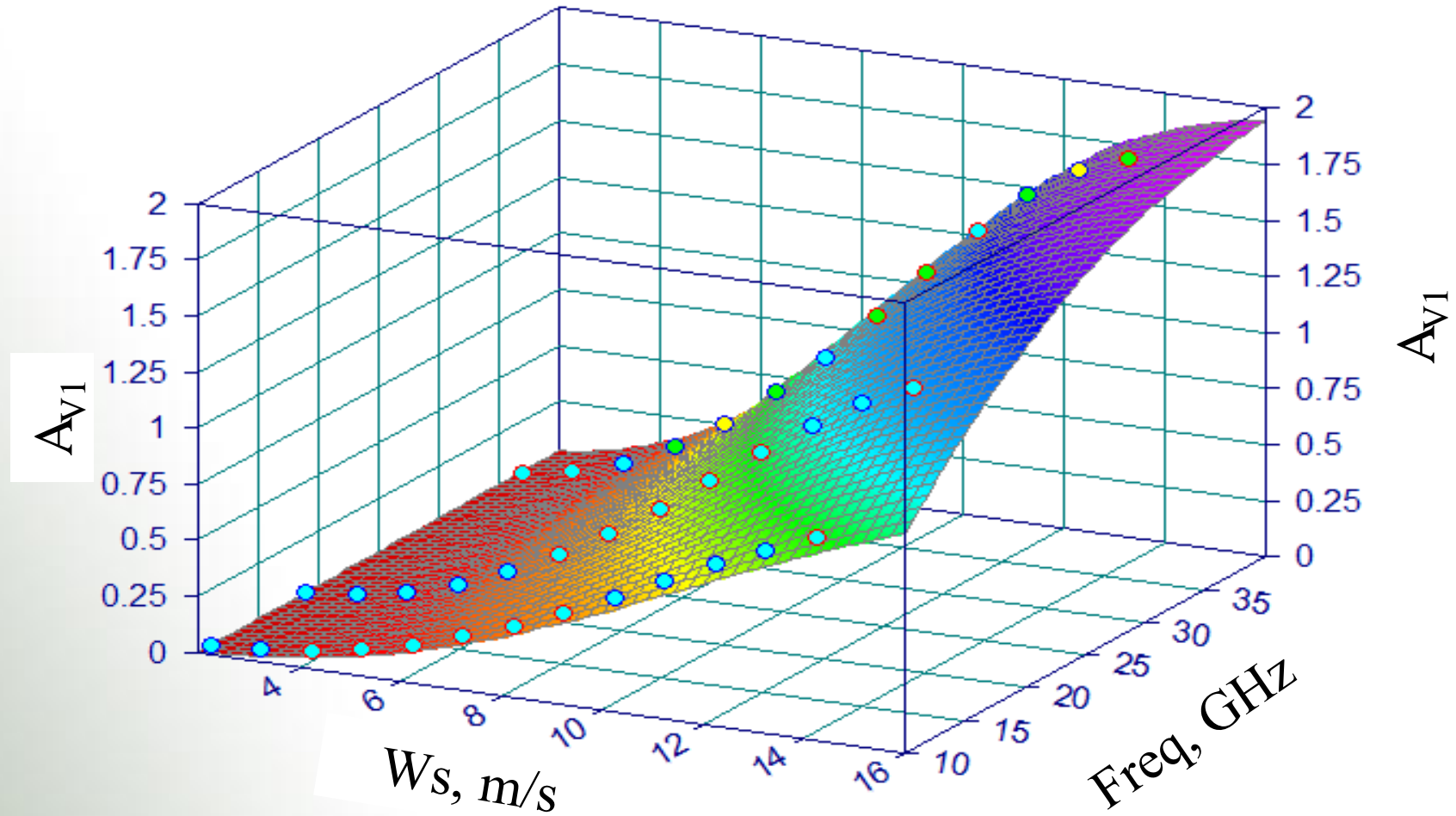

Wind Direction Second Harmonic at 53 degrees, H-Pol

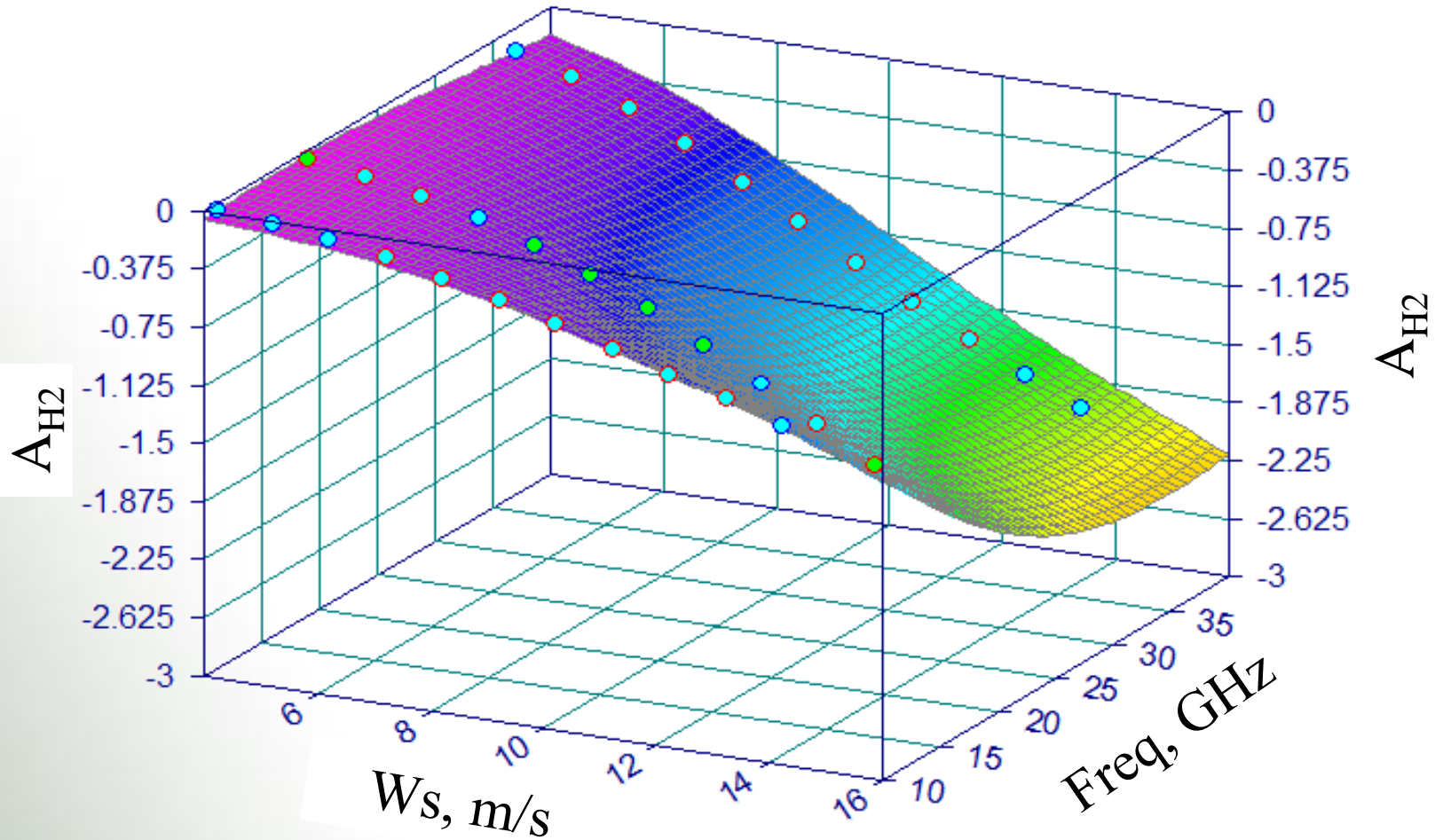

Nadir Wind Direction for 10 GHz

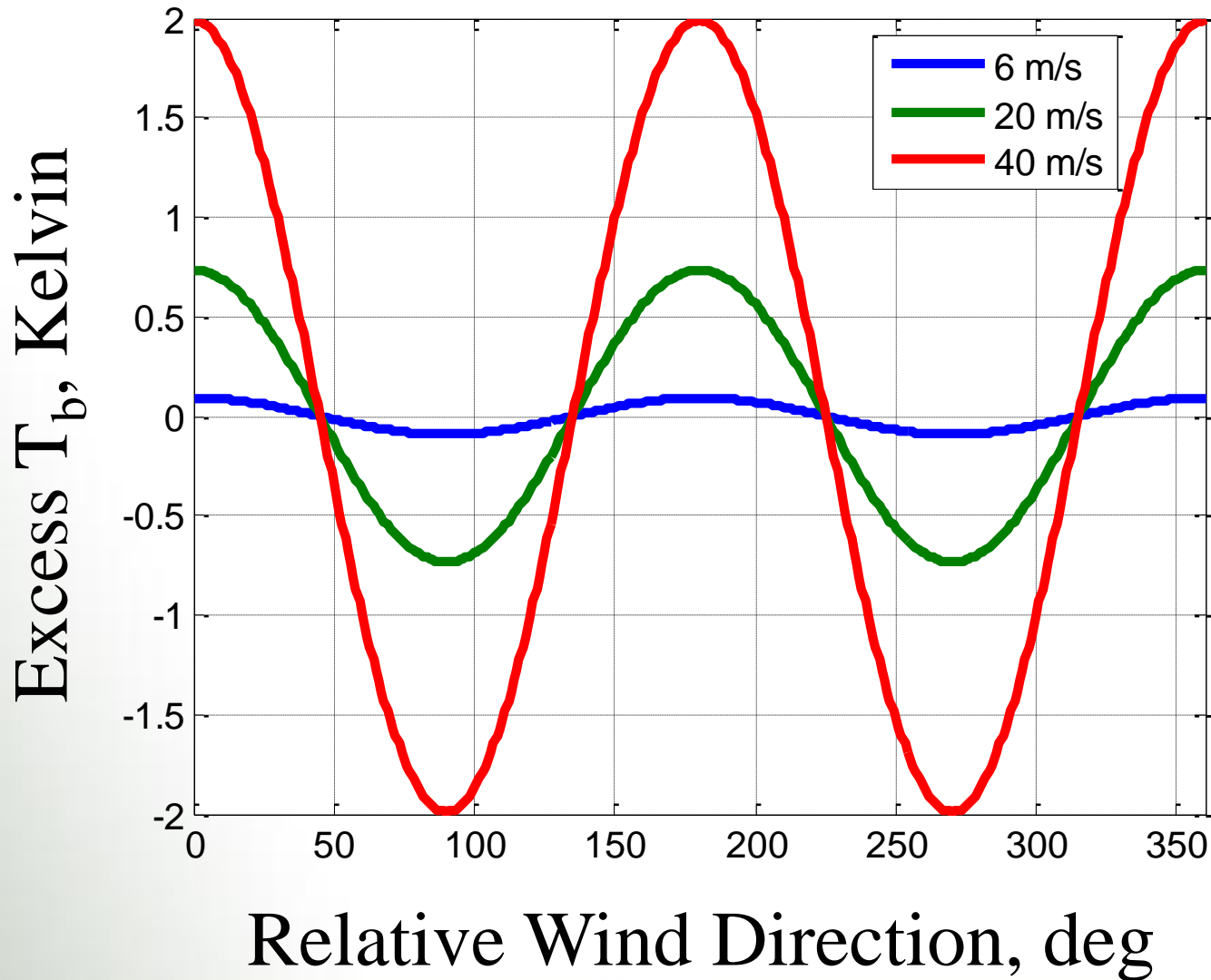

Wind Direction for 10 GHz @ 53 deg



H-Pol

V-Pol

Excess T_b , Kelvin

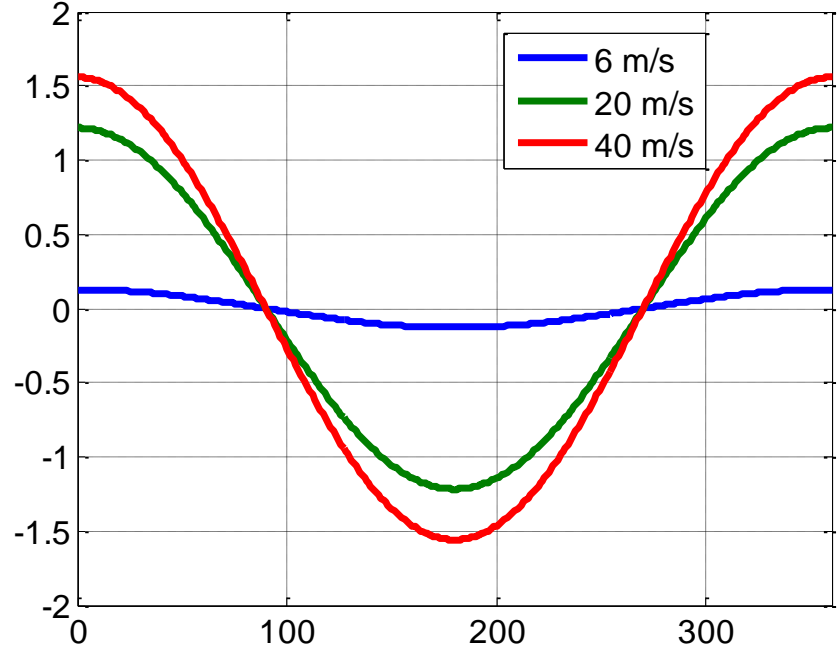
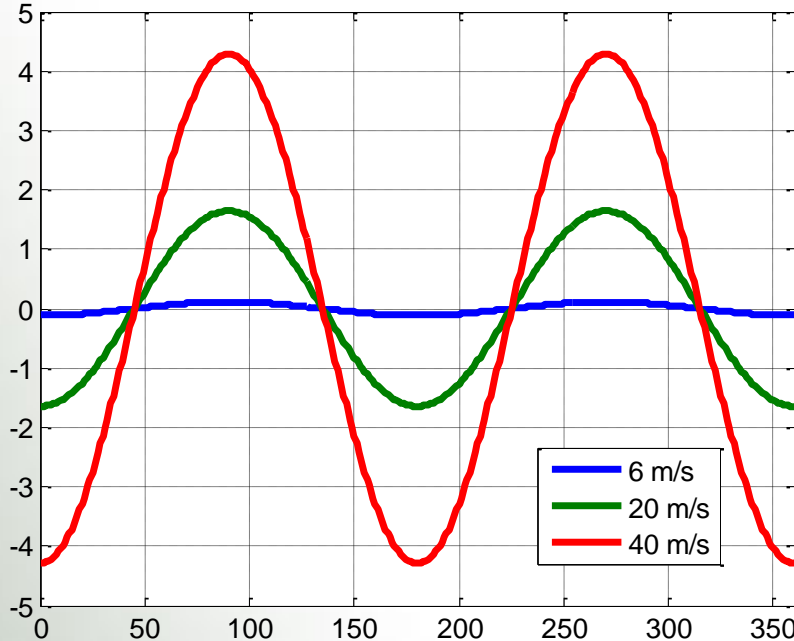

Relative Wind Direction, deg



CFRSL Ocean Total Emissivity Model Results

T_b with respect to EIA

in comparison to Tran et al. (\diamond) & Messiner et al. (\square)



WS = 6 m/s

H-Pol

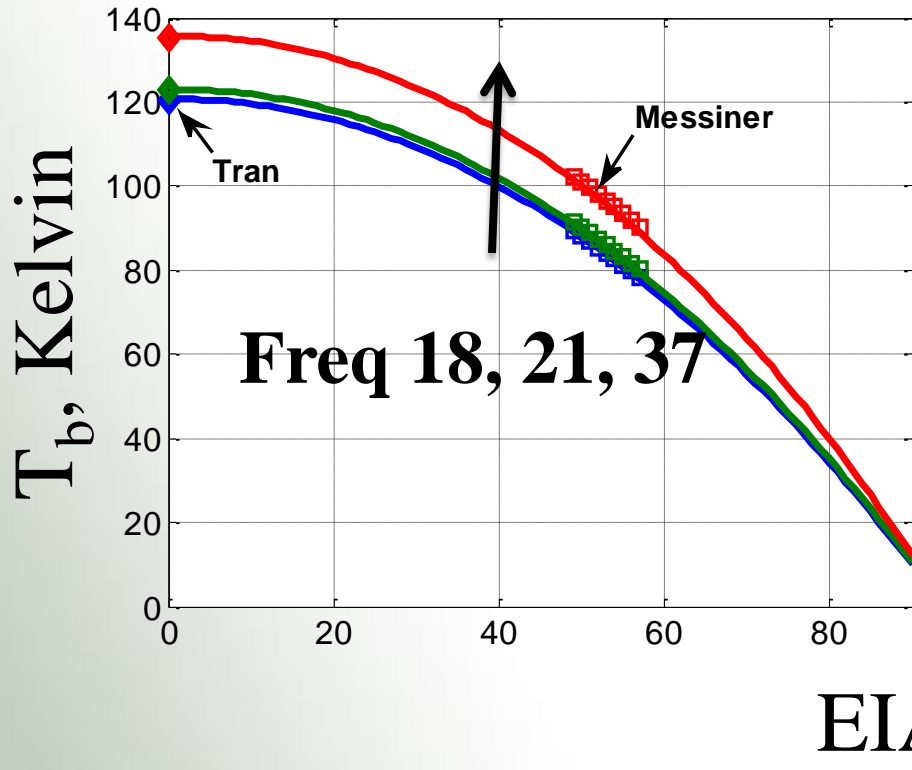

V-Pol

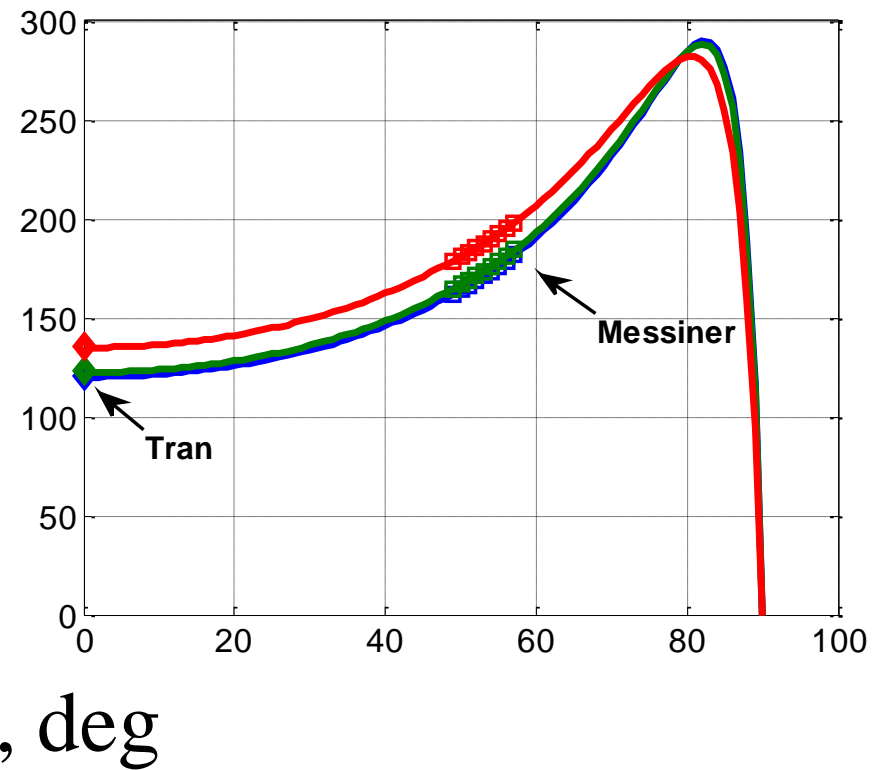

Total Ocean Emissivity Comparisons

$\langle \text{SFMR} \rangle_{\text{freq}} = 6 \text{ GHz}$, $\text{WS}: 5 - 20 \text{ m/s}$



H-Pol

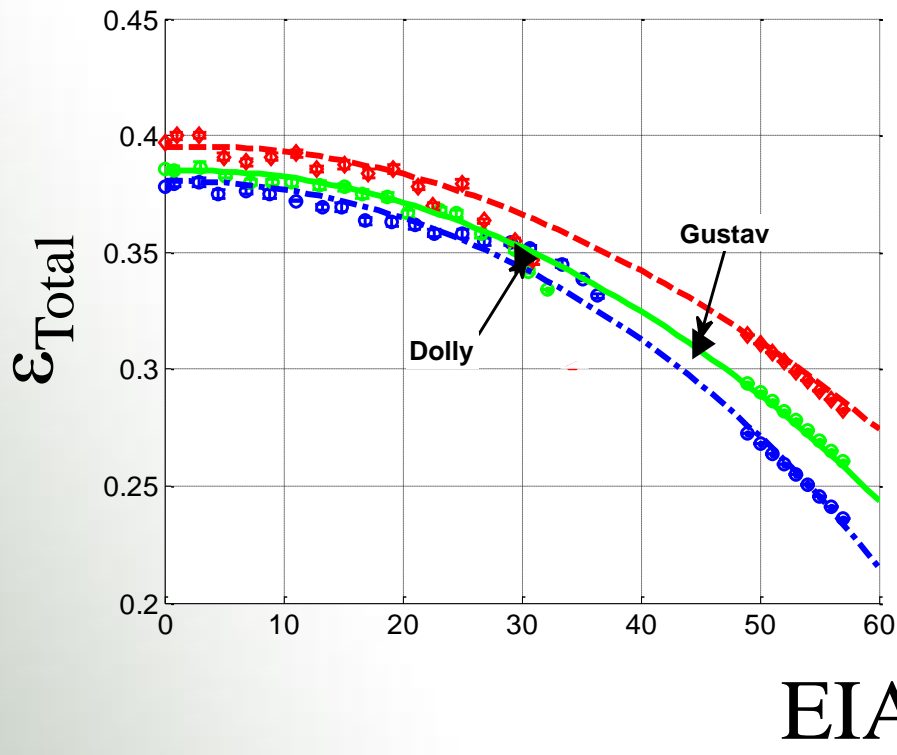

V-Pol

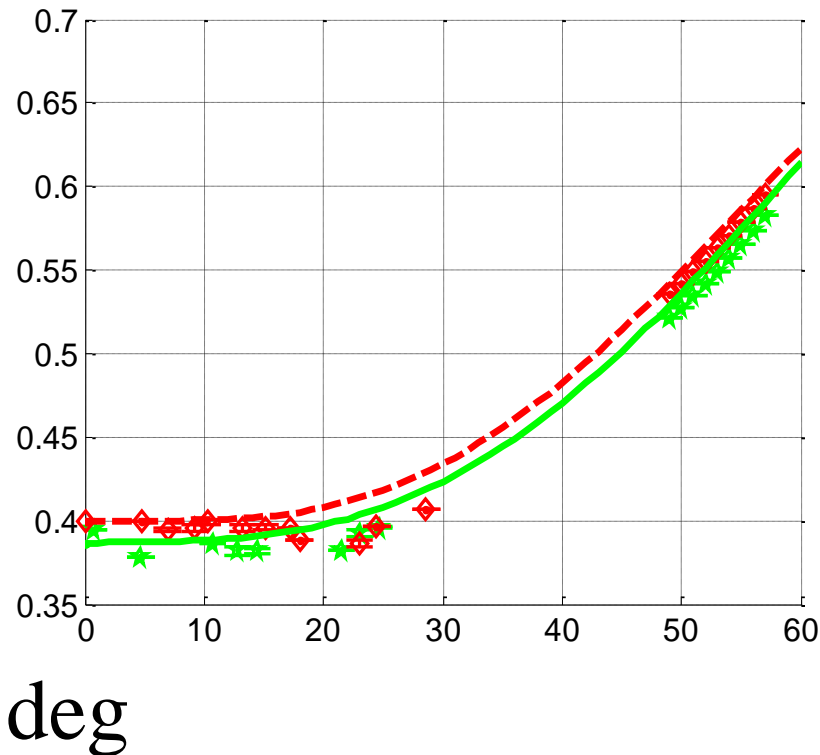

- WS bins of
❖ (5-10 m/s) '○', (10-15 m/s) '*' & '▶', and (15-20 m/s) '◇'

Total Ocean Emissivity

$\langle \text{SFMR} \rangle_{\text{freq}} = 6 \text{ GHz}$, WS: 20 – 45 m/s



H-Pol

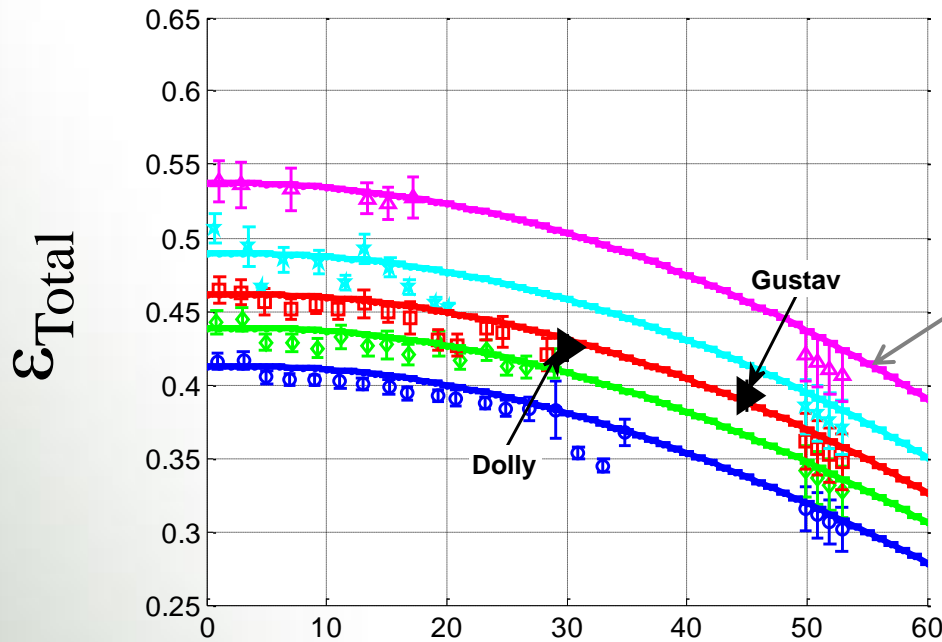

V-Pol

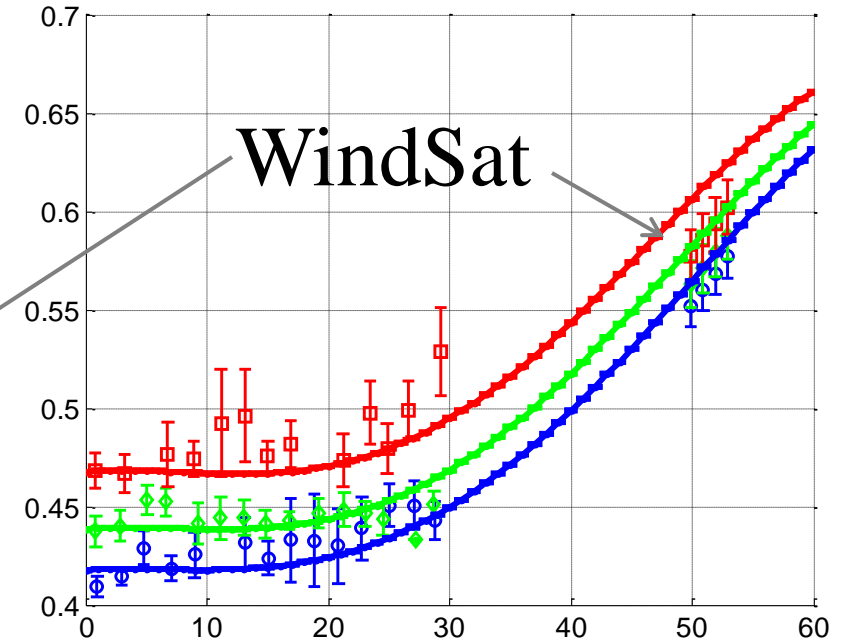

EIA, deg

- WS bins of
- ❖ (20-25 m/s) '○', (25-30 m/s) '◇', (30-35 m/s) '□' & '▶',
 - (35-40 m/s) '✱', and (40-45 m/s) '▲'



Parametric Plots of CFRSL Total Emissivity Model

Emissivity Model Freq Extrapolation @ Nadir

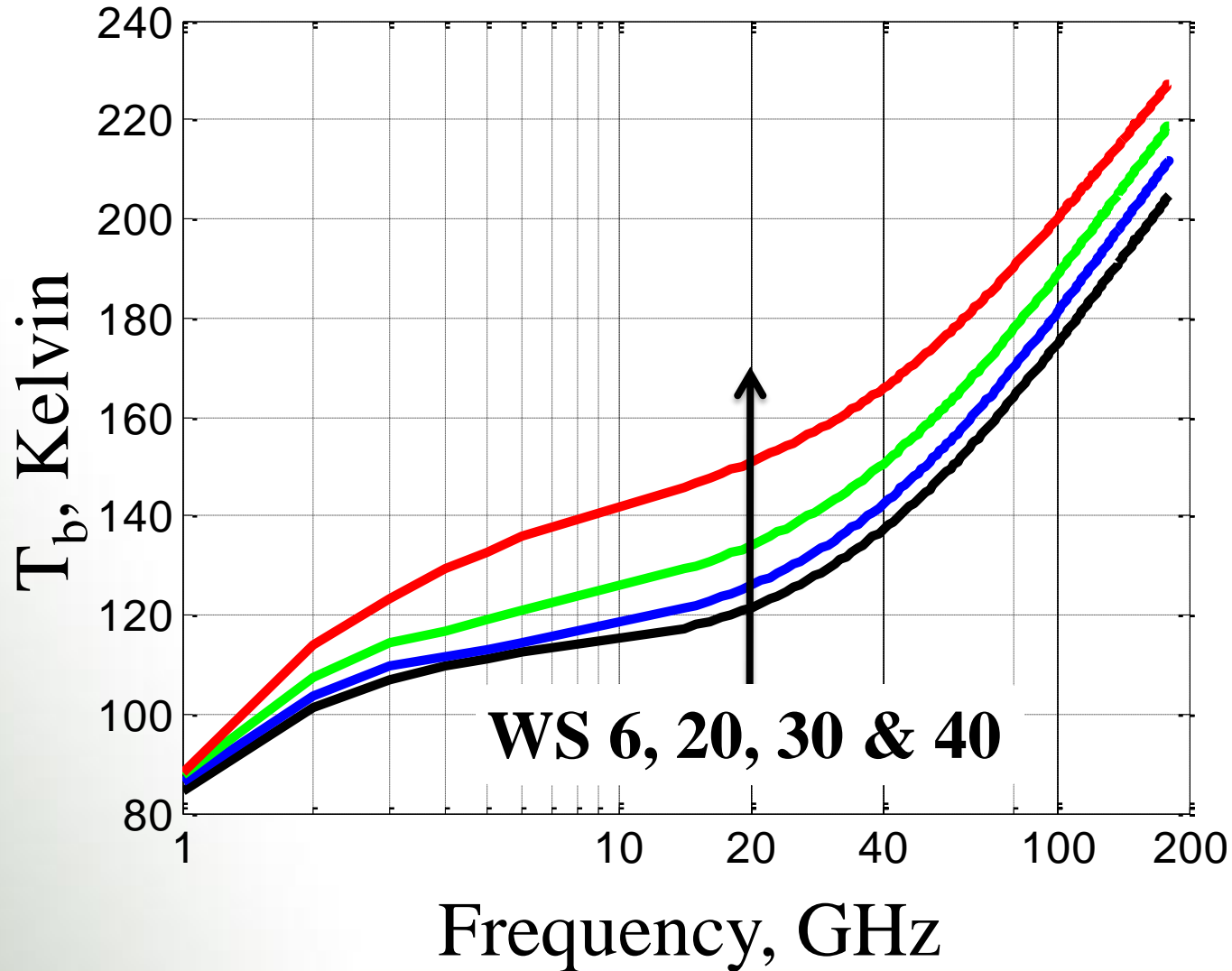

Emissivity Model Freq Extrapolation @ 53 deg EIA



H-Pol

V-Pol

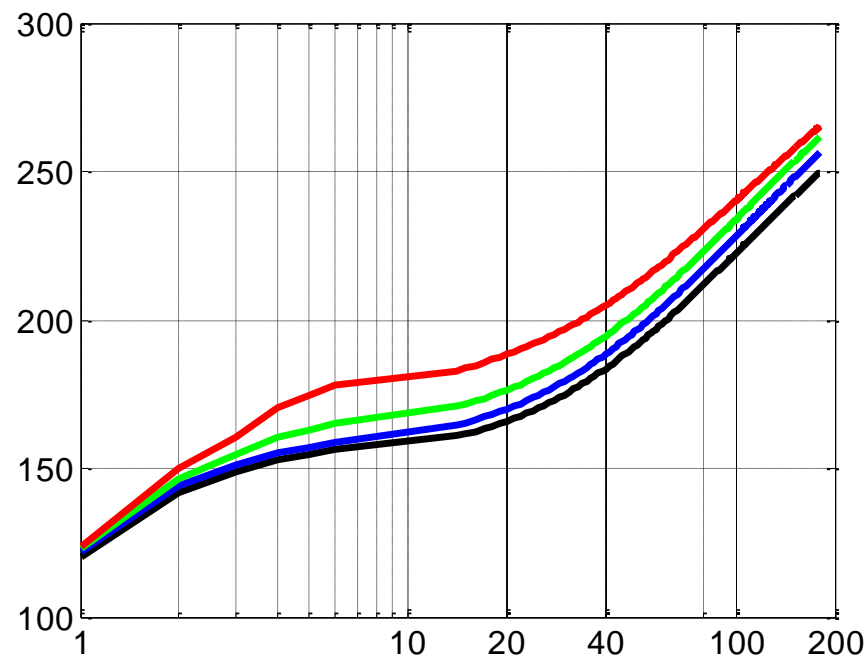
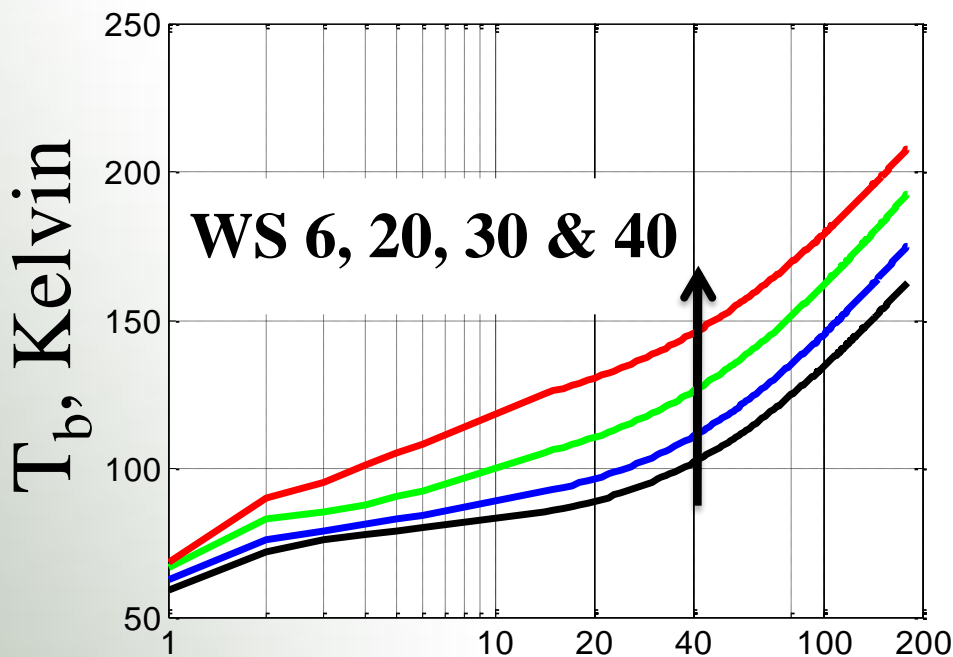

Frequency, GHz

Emissivity Model EIA Extrapolation @ 4 GHz



H-Pol

V-Pol

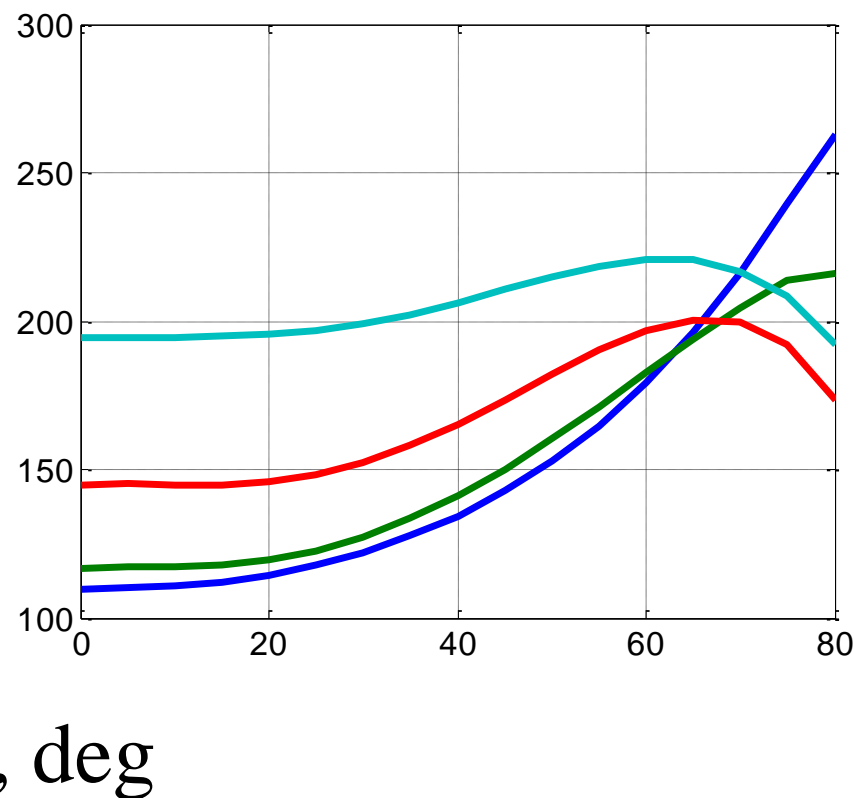
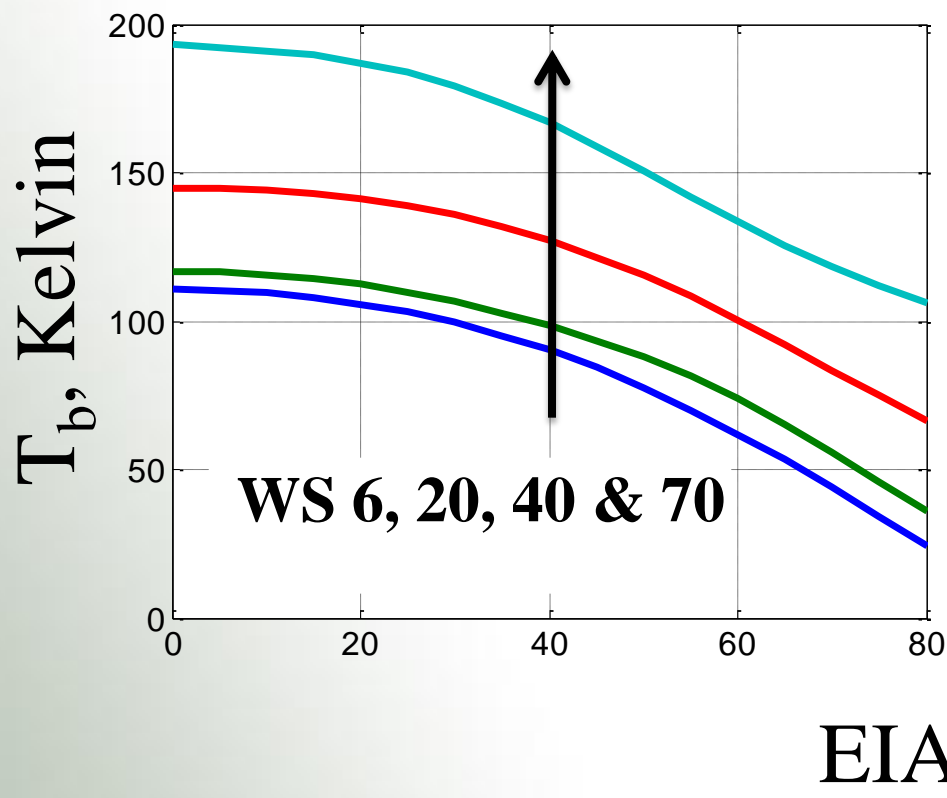

Emissivity Model WS Extrapolation @ 4 GHz

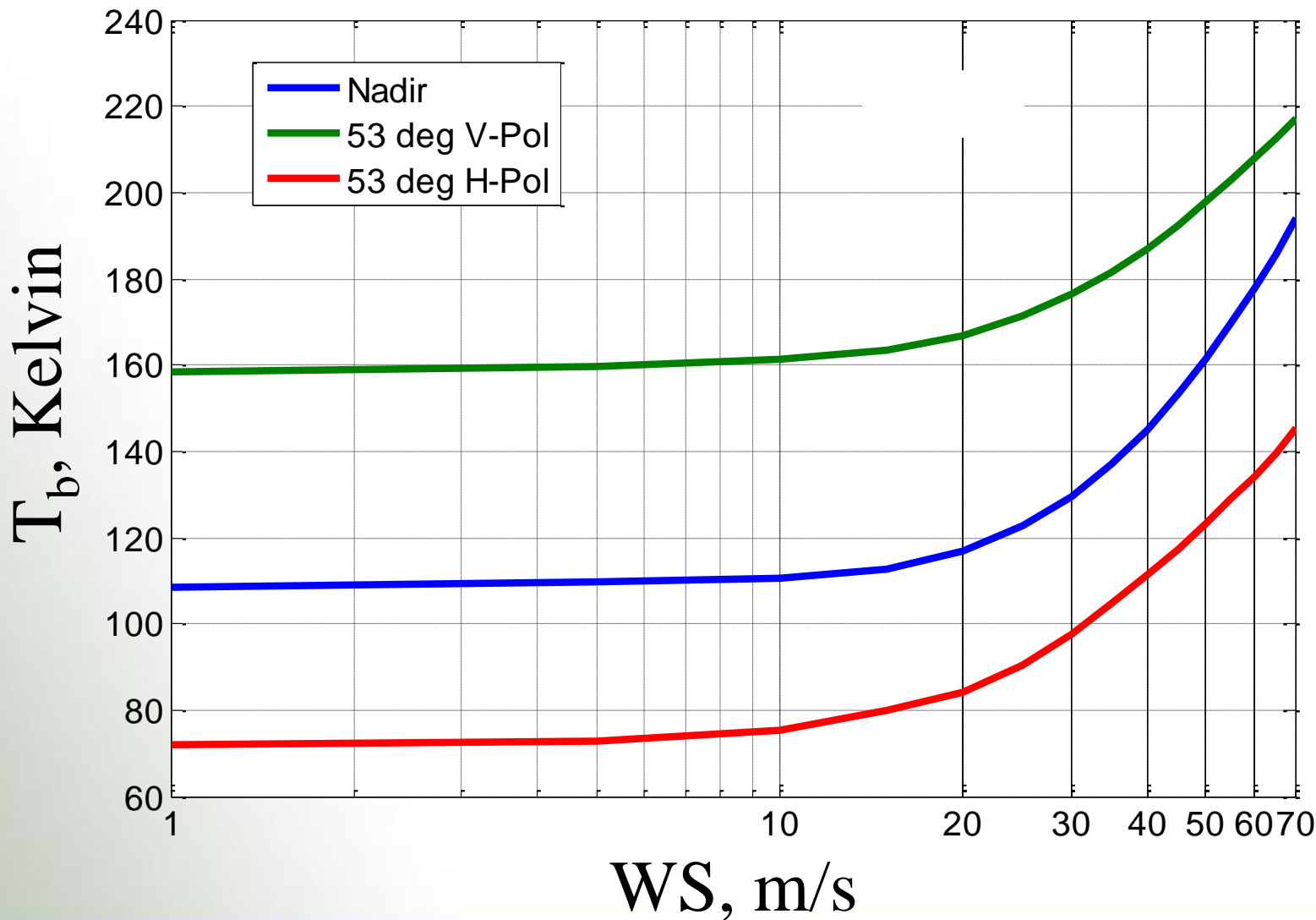

Foam Emissivity Confidence Limits

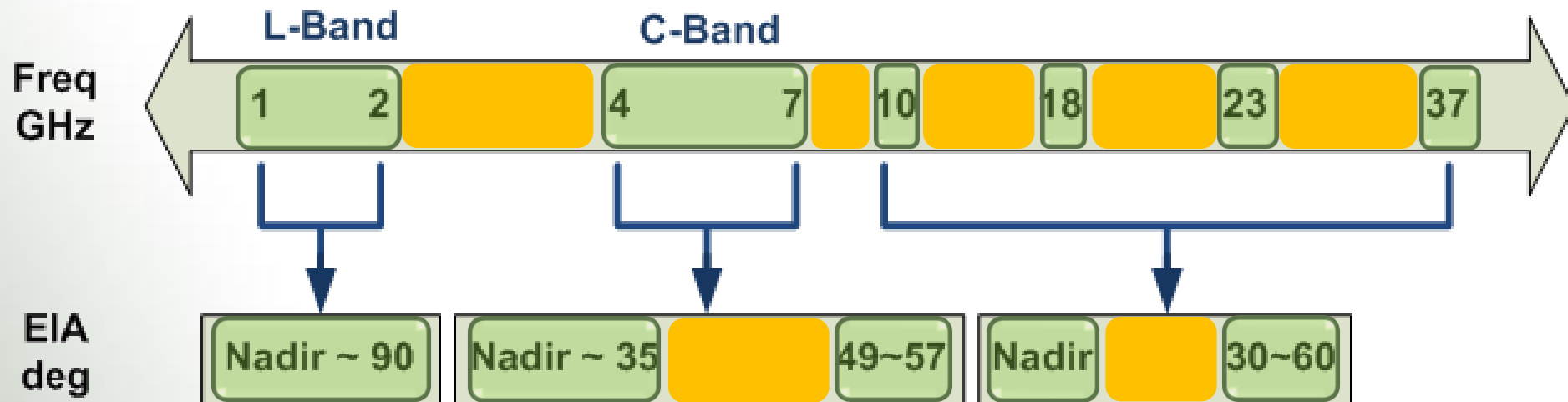

Wind Direction Confidence Limits

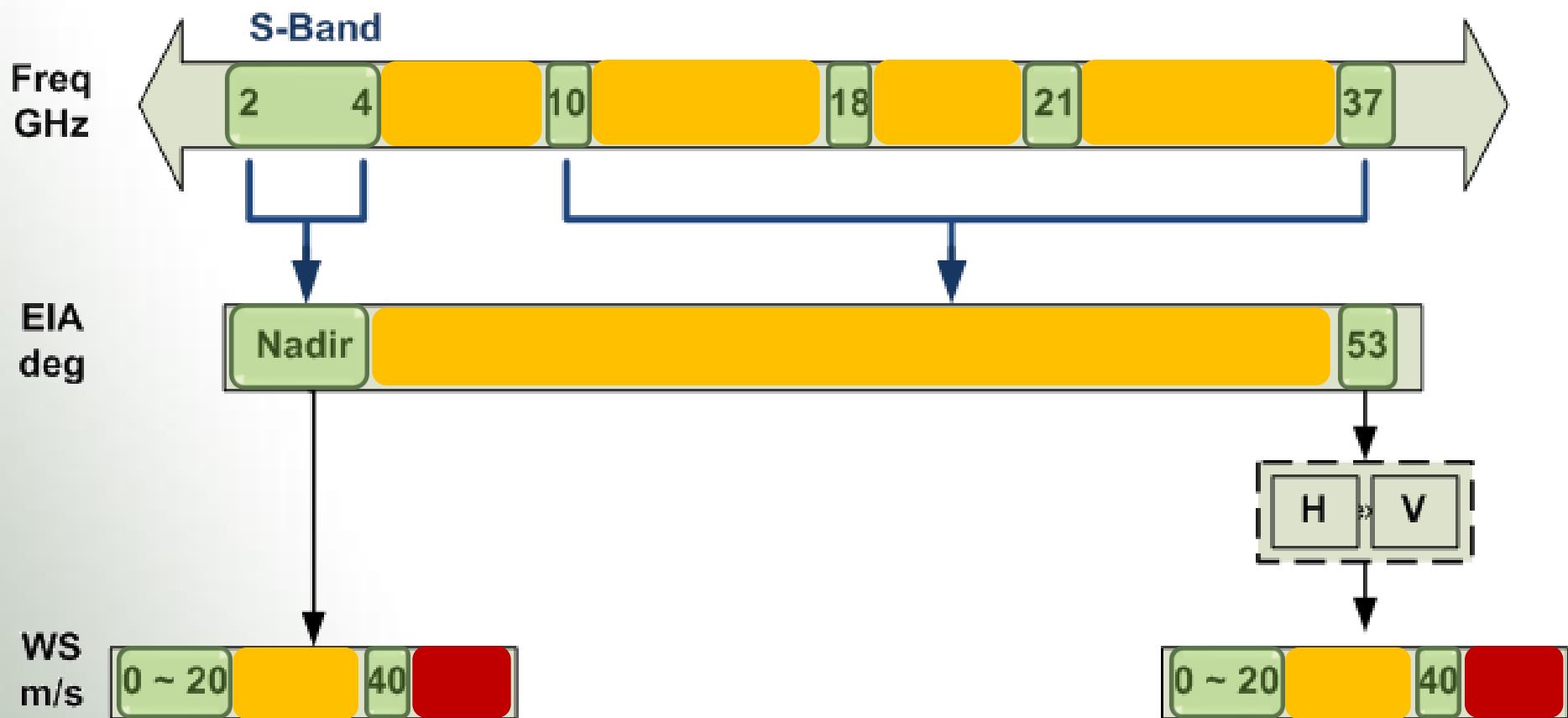

WS Emissivity Confidence Limits

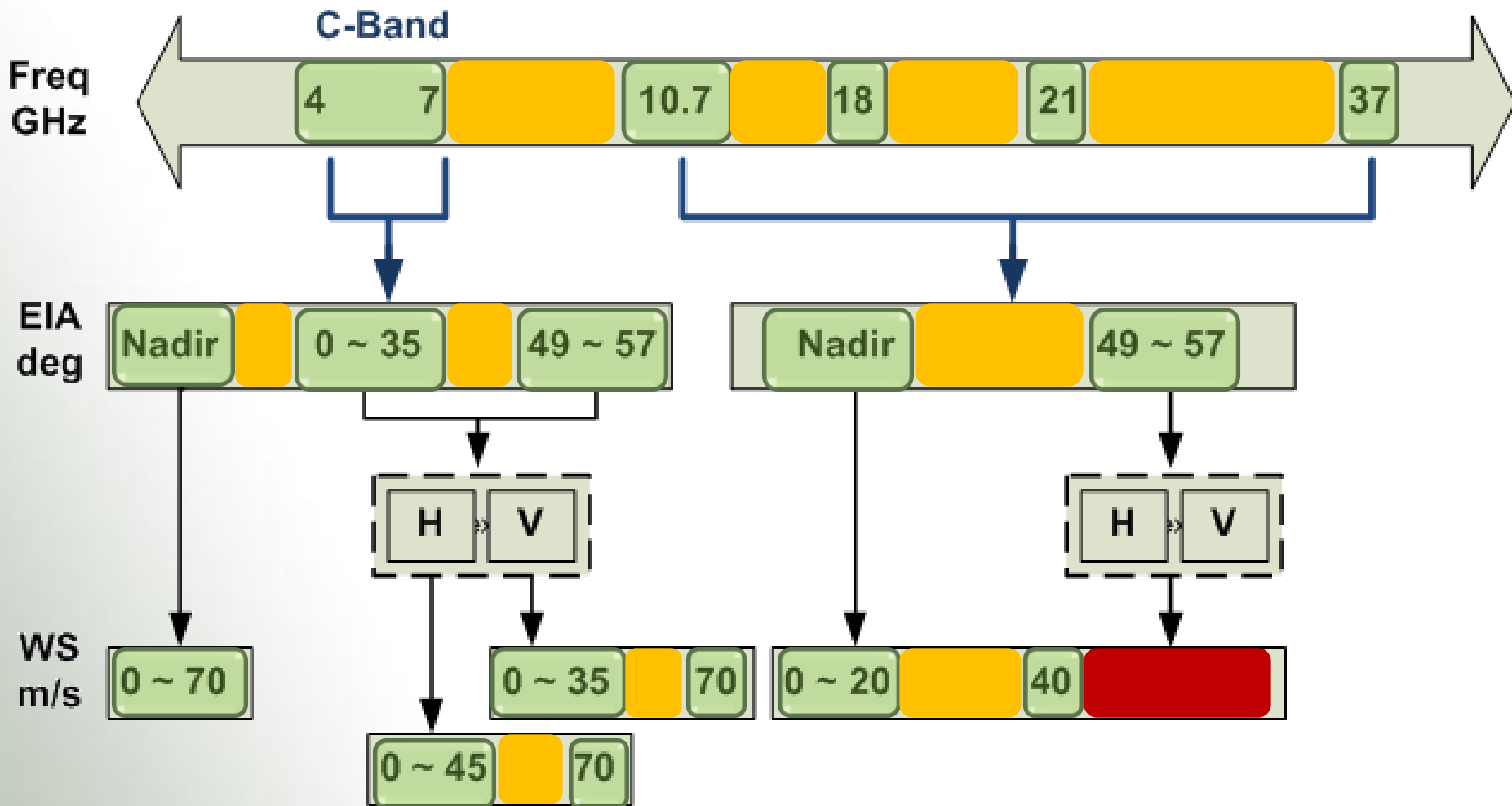

Summary



- A unified physical-based ocean emissivity model has been developed for
 - ❖ Frequency range : 1 - >40 GHz
 - ❖ EIA range : Nadir – 70 degrees
 - ❖ WS: 0 to >70 m/s
 - ❖ Both polarizations (V & H Pol)
 - ❖ Wind Direction
- The model has been implemented in current HIRAD wind speed retrieval error studies



Refereed Publications



- [1] **Salem Fawwaz El-Nimri**, W. Linwood Jones, Eric Uhlhorn, Christopher Ruf , James Johnson, and Peter Black, “An Improved C-band Ocean Surface Emissivity Model at Hurricane-force Wind Speeds over a Wide Range of Earth Incidence Angles” ,presented at IEEE GRSL, 2008 (Accepted, returned for minor revisions)
- [2] Eric W. Uhlhorn, **Salem F. El-Nimri**, Christopher S. Ruf, W. Linwood Jones, ”Sea Surface Passive Microwave Measurements at Large Incidence Angle in Hurricane Conditions,” presented at GRL, 2009 (Under Review)
- [3] B. H. Lim, R. A. Amarin, **S. F. El-Nimri**, J. Johnson, L. Jones, and C. S. Ruf, "Restrictions on the Field of View for an Undersampled 1-D Synthetic Thinned Aperture Radiometry," presented at IEEE GRSL, 2008. (Under Review)



Publications



- [4] **El-Nimri, Salem F.**, Johnson, James and W. Linwood Jones, “Signal Analysis of Microwave Radiometric Emissions in Hurricanes: Part 1 – Ocean wind speed Dependence”, Proc. IEEE SoEastCon, Memphis, TN, Mar. 31-Apr. 1, 2006
- [5] Johnson, James W., Amarin, R. A., **El-Nimri, Salem F.**, and W. Linwood Jones, “A Wide-Swath, Hurricane Imaging Radiometer for Airborne Operational Measurements”, Proc. IEEE IGARSS-06, Aug. 28 - Sept. 1, 2006, Denver, CO.
- [6] Ruba A. Amarin, **Salem F. El-Nimri**, James W. Johnson, W. Linwood Jones, Boon H. Lim and Christopher S. Ruf, “Instrument Design Simulations for Synthetic Aperture Microwave Radiometric Imaging of Wind Speed and Rain Rate in Hurricanes”, presented at IEEE Intrn. Geosci. Remote Sens. Symp., Barcelona, SP., 2007.
- [7] B. H. Lim, R. A. Amarin, **S. F. El-Nimri**, J. Johnson, L. Jones, and C. S. Ruf, "Restrictions on the Field of View for an Undersampled 1-D Synthetic Thinned Aperture Radiometry," presented at IEEE Intrn. Geosci. Remote Sens. Symp, Barcelona, SP., 2007.



Publications



- [8] **S. F. El-nimri**, S. Alsweiss, J. Johnson, L. Jones, R. Amarin, and E. Uhlhorn, “Hurricane Imaging Radiometer Wide Swath Simulation For Wind Speed And Rain Rate”, presented at IEEE Intrn. Geosci. Remote Sens. Symp, Boston, Massachusetts, 2008
- [9] **S. F. El-nimri**, S. Alsweiss, J. Johnson, L. Jones, and C. Ruf, “Improved microwave remote sensing of hurricane wind speed and rain rates using the Hurricane Imaging Radiometer (HIRAD)” Submitted to The 28th Conference on Hurricanes and Tropical Meteorology, special session on “Advances in Remote Sensing of Tropical Cyclones”, 2008
- [10] **Salem F. El-Nimri**, James W. Johnson and W. Linwood Jones and E. Uhlhorn,”Development of an Ocean Surface Emissivity Model for Wide Swath Imaging of Wind Speed to Hurricane Force,” presented at IEEE Intrn. Geosci. Remote Sens. Symp, Barcelona, SP., 2007.
- [11] S. AlSweiss, W.L. Jones, P. Laupattarakasem,**S. EL-Nimri**, S. Veleva, B. W. Stiles, E. Rodriguez, and R. W. Gaston, “Simulated OVW Retrievals in Tropical Cyclones for the Next Generation Dual Frequency Scatterometer”, Ocean-09 Conference, 26-29 Oct. 2009, Biloxi, MS.



Conference Presentations



- [12] Johnson, James W., Amarin, Ruba A., **El-Nimri, Salem F.**, and W. Linwood Jones, “A Wide Swath, Imaging Microwave Radiometer for Hurricane Observations”, 60th InterDepartmental Hurricane Conference, Mobile, AL, Mar. 21-24, 2006
- [13] Timothy Miller, Robert Atlas, M. C. Bailey, Peter Black, **Salem El-Nimri**, Robbie Hood, Mark James, James Johnson, Linwood Jones, Christopher Ruf, and E. Uhlhorn, "Surface Wind Vector and Rain Rate Observation Capability of Future Hurricane Imaging Radiometer (HIRAD)," in *63rd Interdepartmental Hurricane Conference* St. Petersburg, Tampa, 2009.
- [14] W. L. Jones , P. Laupattarakasem, S. AlSweiss, **S. El-Nimri**, S. Veleva, B. W. Stiles, E. Rodriguez, and R. W. Gaston, “Simulated OVW Retrieval Performance for the Dual Frequency Scatterometer in Hurricanes”, poster presented at NASA Ocean Vector Wind Science Team Meeting, 18-20 May 2009, Boulder, CO.
- [15] Eric Uhlhorn, Robert Atlas, Peter Black, Courtney Buckley, S. Chen, **Salem El-Nimri**, Robbie Hood, James Johnson, Linwood Jones, Timothy Miller, and C. Ruf, "Simulation of the Impact of New Aircraft- and Satellite-Based Ocean Surface Wind Measurements on Estimates of Hurricane Intensity," in *63rd Interdepartmental Hurricane Conference* St. Petersburg, Tampa, 2009.



BackUp Slides

BackUp explanation for slide 53



T_b , Kelvin

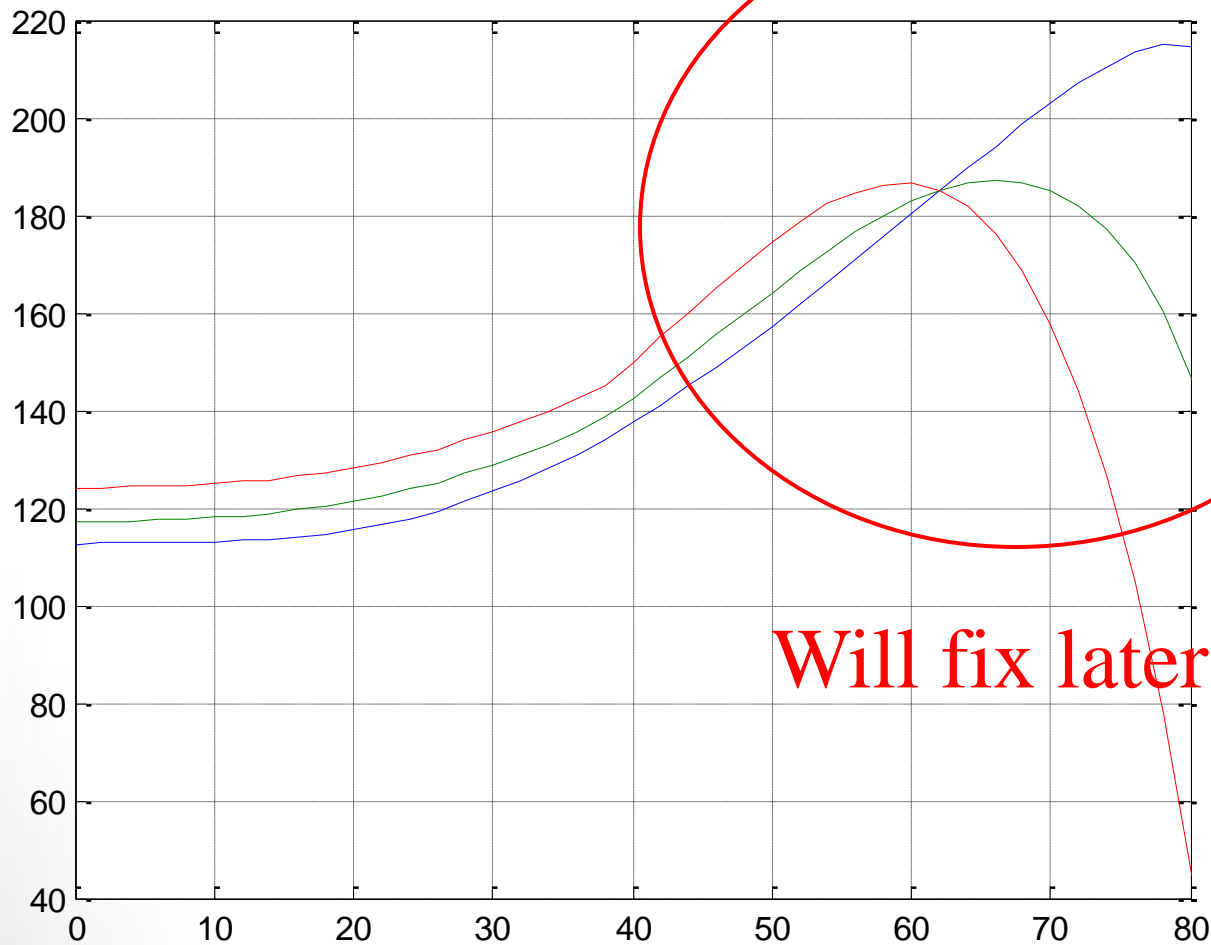

Will fix later

EIA, deg



Nadir WD

Nadir Wind Direction

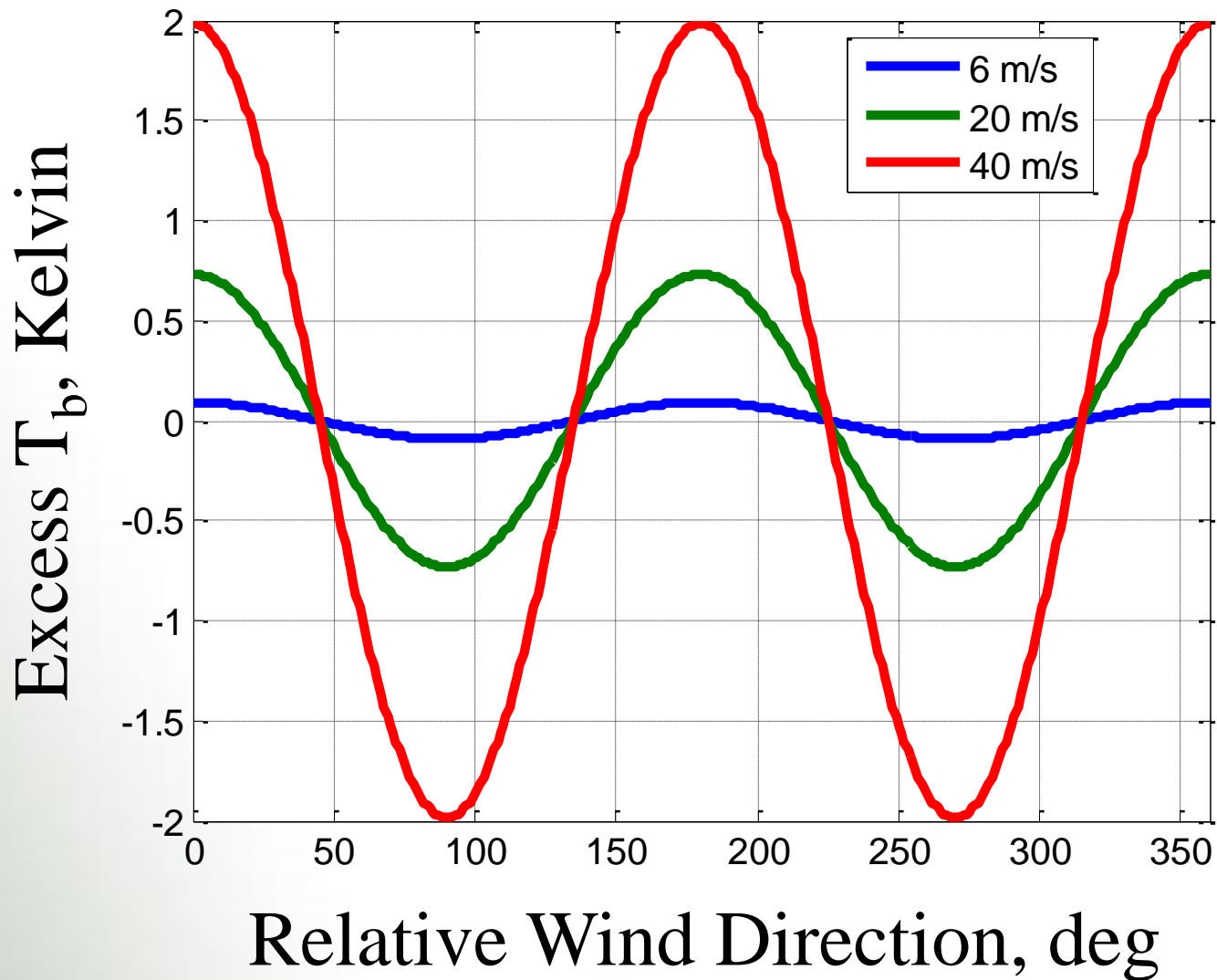

37 GHz

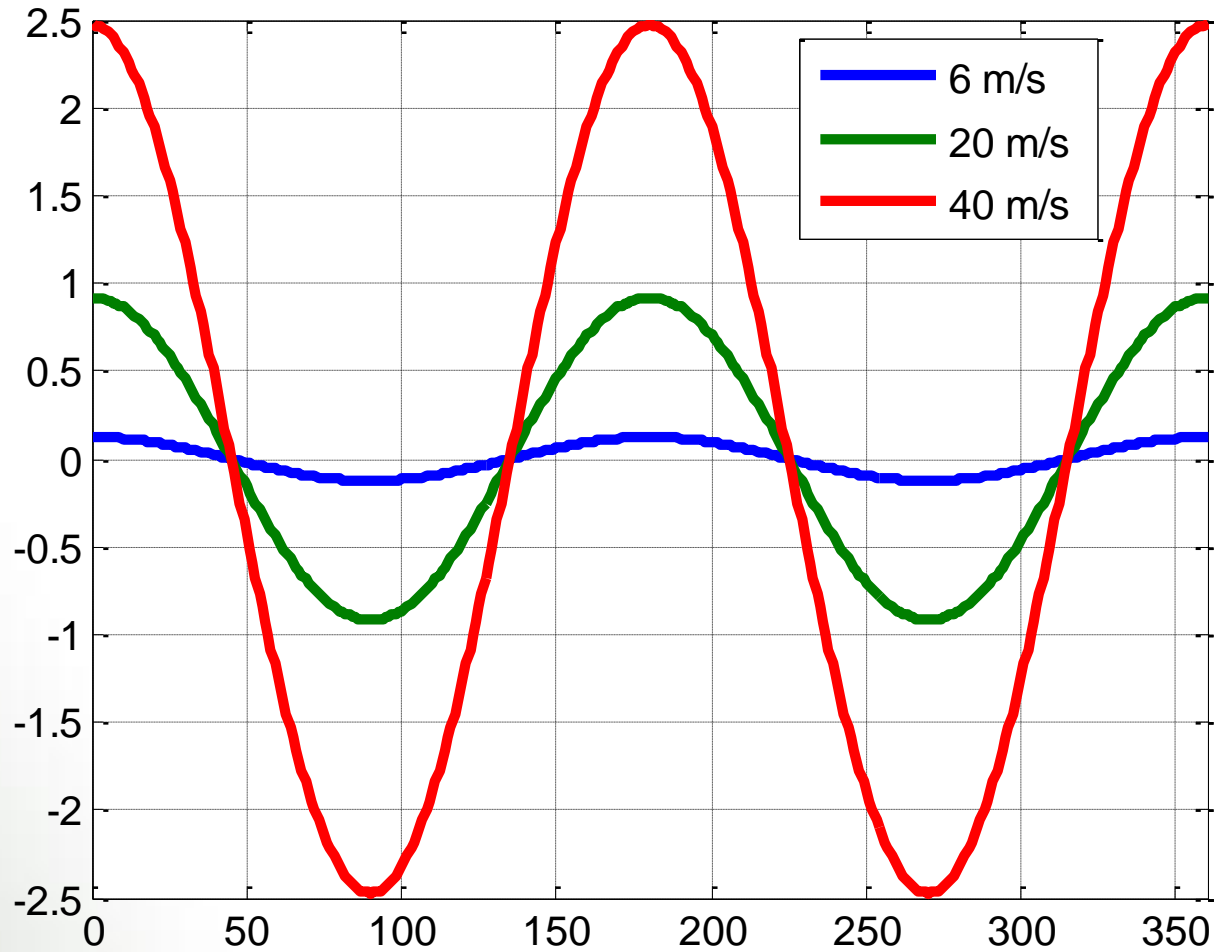



53 degree WD

Foam Emissivity V-Pol in comparison to Rose et al. (○)

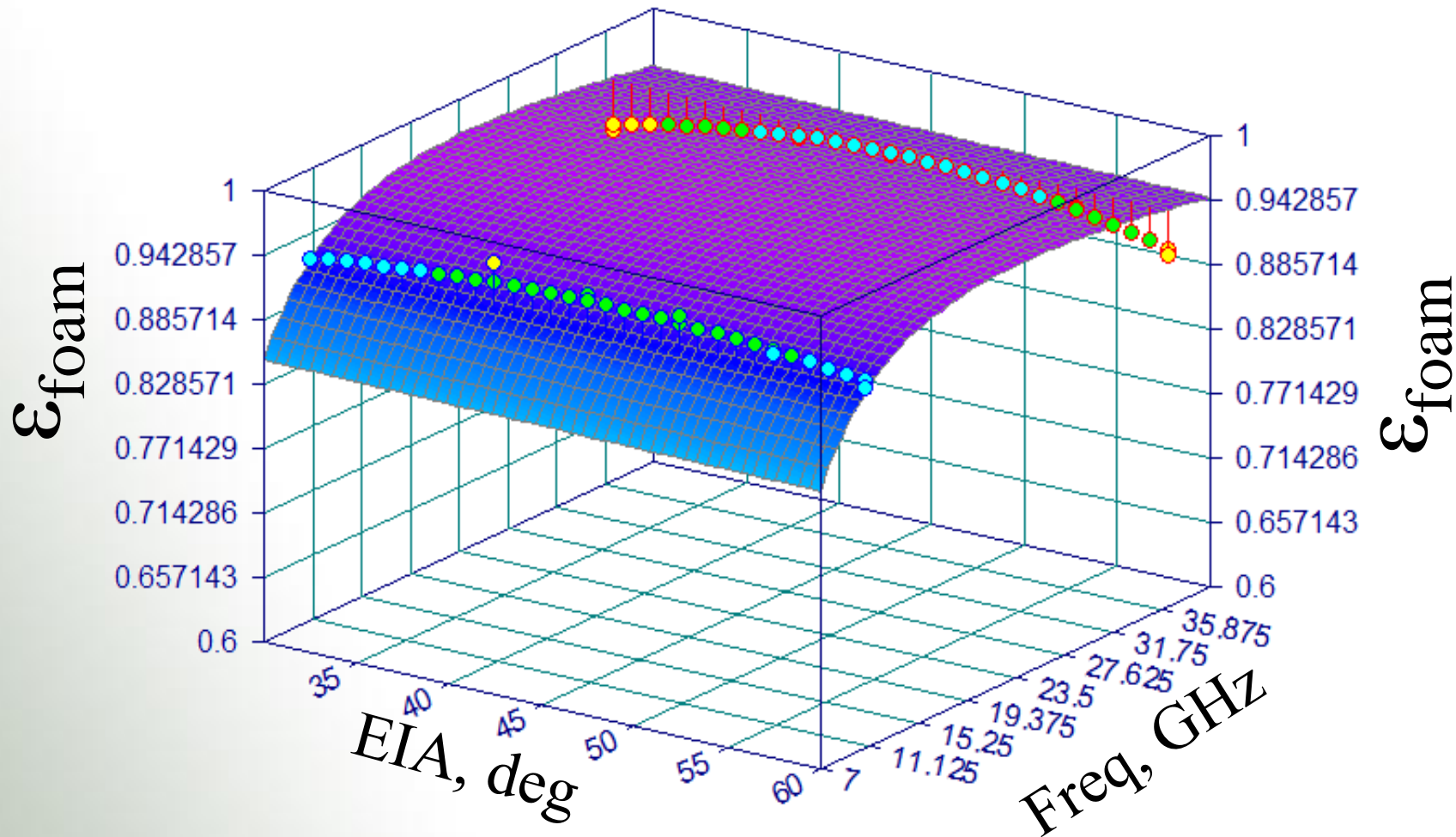

Foam Emissivity H-Pol in comparison to Rose et al. (○)

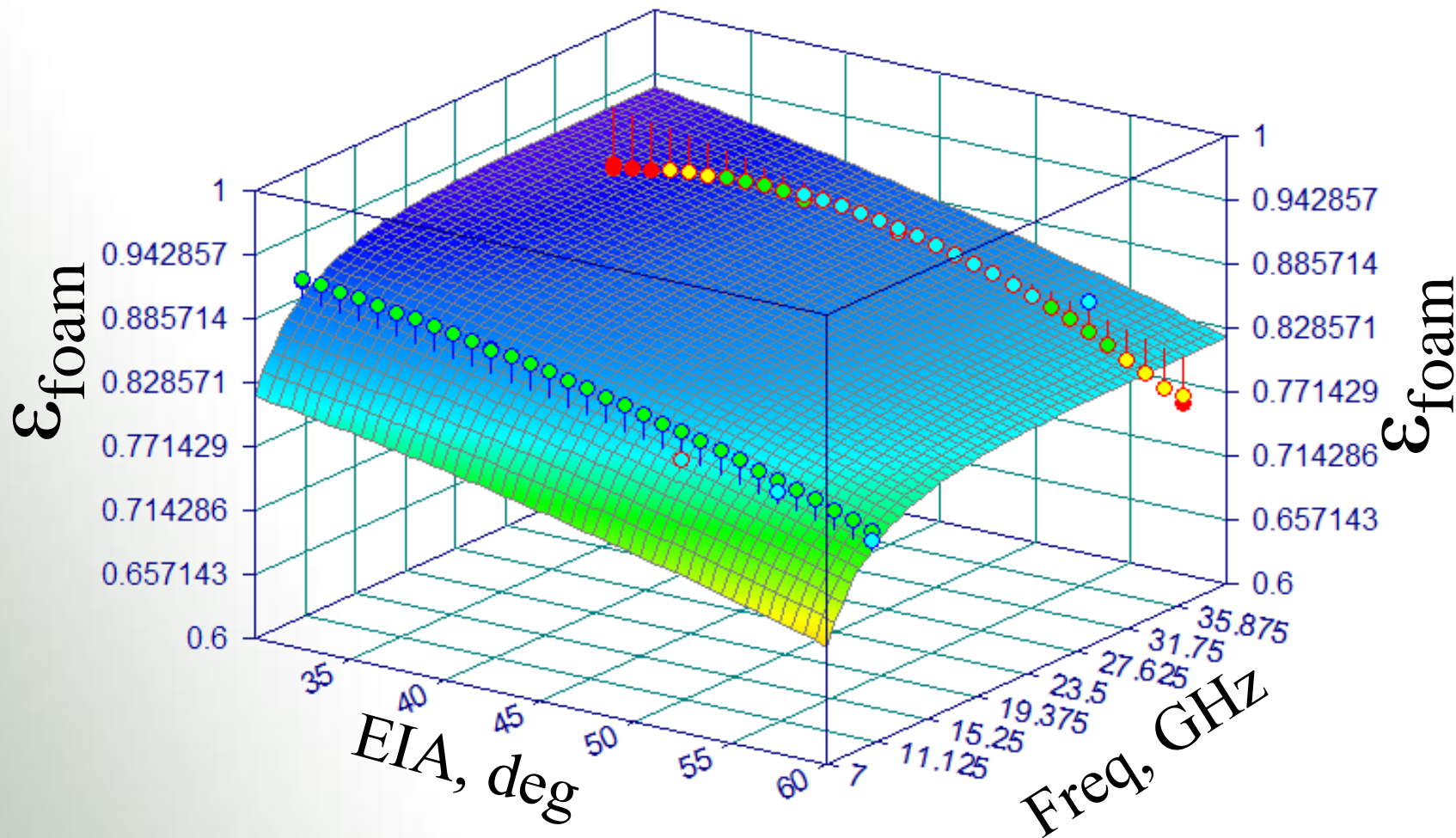

Nadir Wind Direction 4 GHz, 53 deg



H-Pol

V-Pol

Excess T_b , Kelvin

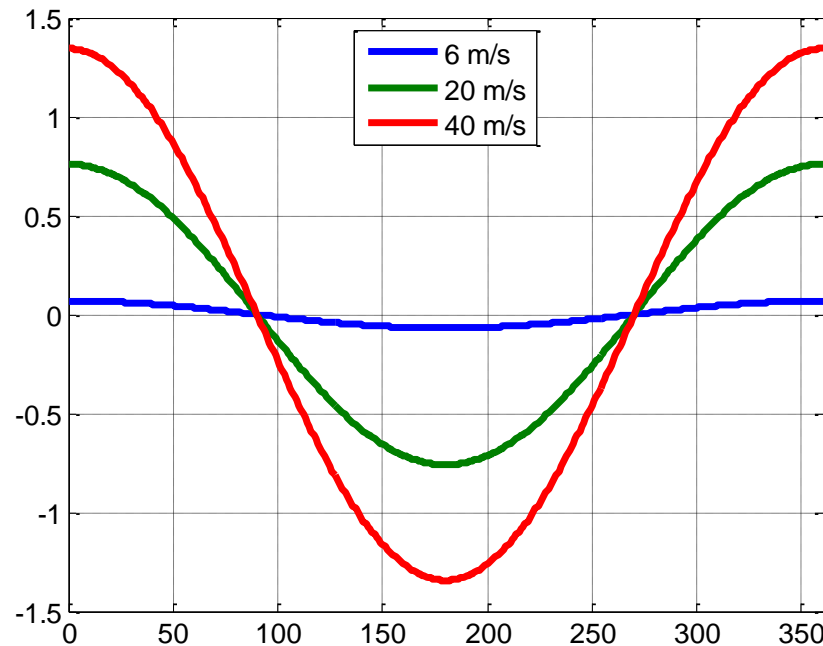
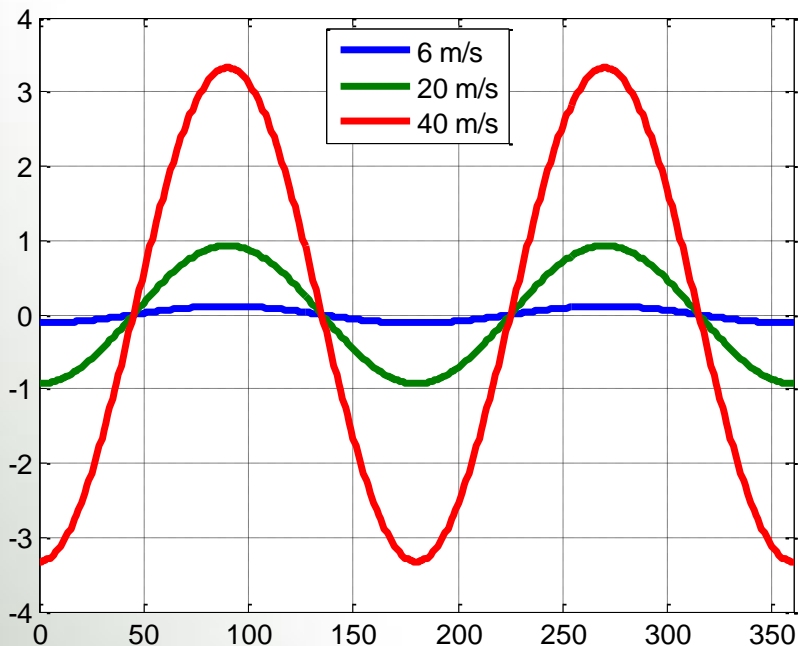

Relative Wind Direction, deg

37 GHz

